

R&D INFRASTRUCTURE TASK FORCE FINAL REPORT

Key recommendations to support essential
R&D infrastructures for Generation IV Nuclear Energy Systems

January 2021



Contents

PREFACE	3
I. INTRODUCTION	5
II. APPROACH	6
III. SFR R&D INFRASTRUCTURES	9
IV. LFR R&D INFRASTRUCTURES	17
V. GFR R&D INFRASTRUCTURES	25
VI. VHTR R&D INFRASTRUCTURES	32
VII. SCWR R&D INFRASTRUCTURES	37
VIII. MSR R&D INFRASTRUCTURES	52
IX. CROSS-CUTTING R&D INFRASTRUCTURES	57
X. MECHANISMS AND APPROACHES FOR COLLABORATIVE R&D ACTIVITIES	74
XI. KEY RECOMMENDATIONS	81
XII. CONCLUSIONS	84
XIII. APPENDIX	85

PREFACE

The Generation-IV International Forum (GIF) is a cooperative international framework dedicated to carry out the research and development needed to establish the feasibility and performance capabilities of the next generation nuclear energy systems. The GIF's four goals remains since its early beginning: Sustainability, Economics, Safety & Reliability, and Proliferation Resistance and Physical Protection (PR&PP). We recently add the search of a new asset: Flexibility.

GIF is gathering now 14 members' countries and the most active R&D organizations working on Gen-IV systems are involved. GIF is organized around three crosscutting methodology working groups (WG on economics, PR&PP, Risk & Safety), and still six reactor System Arrangements. The six reactor systems are Sodium-cooled Fast Reactor (SFR), Lead-cooled Fast Reactor (LFR), Very High Temperature Reactor (VHTR), Gas-Cooled Fast Reactor (GFR); Supercritical Water-Cooled Reactor (SCWR) and Molten Salt Reactor (MSR).

In its role, the GIF community is always seeking to foster international exchange and to find synergies between facility owners, and experimental programs to be performed. There was a clear statement that the R&D facilities in support of Gen-IV systems are very specific mainly due to Gen-IV systems particular coolants: Liquid Metals, Gas (helium), Molten Salts, SuperCritical water, and Supercritical CO₂ for some Energy Conversion Systems. These coolants are not (often) used in other industries. Consequently, the overall facility fleet gathered by all the Gen-IV research organizations is – in such a way – a living treasure and we have to be aware of it. We also have to make it grow and to share among those who need to use it.

This was the very essence of the role given to this Task Force called RDTF (R&D Infrastructure Task Force) in order to get a clear view of our joint capabilities, to identify assets needs and gaps, and to identify the financial and legal mechanisms to perform a better shared-use of this treasure. Consequently, the following document is dealing with all these objectives and is providing an accurate picture of the today situation and forecast for the coming years.

Moreover, with the growing interest of the Private Sector in all SMR' systems, this document is also a good opportunity for them to realize the huge potentiality of the GIF facility fleet, and how to get closer access to its use. For the GIF community it is its role to ease and simplify the way to interconnect worldwide R&D organizations, private sectors with R&D teams, different national projects, in order to reach higher complementarity, efficiency, synergies and a higher use of these facility fleets. At the end, the gain will fall back on all systems development progress and knowledge.

I want to thank all contributors of this Task Force, producing this document that was accompanied by a related GIF Workshop in Feb. 2020 in Paris (see on the GIF Website). These two materials must be considered as a real springboard for a future enhancement of R&D facility use in the future. Contributors deserve to be congratulated for the nice opportunities opened. A very special thank is addressed to **Roger Garbil** who led this Task Force and kept its target on-line during all this period.

Gilles Rodriguez

Technical Director of the
Generation-IV International Forum

ACKNOWLEDGEMENTS

This research and infrastructure assessment was supported by institutions, research organizations, industry, companies or individuals involved within GIF research projects and its Task Force on research Infrastructures. We are also thankful to colleagues who provided expertise that greatly assisted the research effort accumulated in this report.

I. INTRODUCTION

The Generation-IV International Forum (GIF) is a co-operative international endeavor coordinating the research and development (R&D) needed to establish the feasibility and performance of the next generation (Gen-IV) nuclear energy systems. This document summarizes the results of the GIF R&D Infrastructure Task Force (GIF RDTF).

The GIF-RDTF was established early 2018, for a period of up to two years, as approved by the 44th GIF Policy Group in Cape Town (South Africa), in October 2017. A brief introduction of the Terms of Reference (ToR) and objectives is provided.

The initial step was to 'Identify essential R&D experimental facilities needed for development, demonstration and qualification of Gen-IV components and systems, including activities to meet safety and security objectives. Major (or critical) experimental infrastructure (or facilities) needs to support Generation-IV systems (SFR, LFR, GFR, VHTR, SCWR and MSR) R&D objectives for the next decade (i.e. viability, performance, or demonstration – depending on the respective system Technological Readiness Level - TRL) are presented, based upon national R&D programs and considering industrial needs.

Identification of existing experimental facilities in response to the aforementioned needs highlighted some gaps. Planned experimental infrastructure constructions and availability of experimental infrastructures outside the GIF countries are briefly discussed.

Forward looking and planned activities of GIF RDTF in view of meeting its **second objective** are discussed, the latest being to 'Promote the utilization of the experimental facilities for collaborative R&D activities among the GIF partners'. To this end, identify existing mechanisms and approaches, including organizational points of contact, for obtaining access to relevant R&D facilities in the GIF member countries is needed. This information should then be made accessible to GIF participants and R&D organization, e.g. through the GIF website, the GIF members network, including closer OECD/NEA, GIF and IAEA international cooperation initiatives, to stimulate joint funding from Member States and/or enterprises, and benefits to be capitalized.

First conclusions and outlook of the GIF RDTF to ensure a successful implementation of the Generation-IV Systems' Experimental Infrastructure Needs are provided within sections XI and XII.

II. APPROACH

At the 43rd GIF Policy Group (PG) meeting held on 13-14 April 2017 in Paris, France, the GIF Board decided to establish a new Task Force (TF) on R&D Infrastructure. The PG tasked the Technical Director (TD) to develop, in collaboration with the PG vice chair in charge of external collaboration and with the Technical Secretariat (TS), the Terms of Reference (ToR) for the future GIF R&D Infrastructure Task Force.

This task Force was initiated around each Gen-IV System Steering and provisional System Steering Committee (SSC and pSSC) and Expert Group (EG) designated representatives. It reports to the PG vice-chair in charge of external collaboration. Members meet as needed, taking advantage of audio- and tele- conferences when practical. At its kick-off meeting on 19 February 2018, it determined its chair and vice chairpersons, agreed upon a two-year work plan, deliverables and milestones, taking advantage of relevant work of IAEA and NEA in the area of experimental infrastructures to perform R&D studies. With the approval of the PG in Sun Valley, USA, on 17-18 May 2018, a goal was set to complete its first objective in due time, for presentation at the October 2018 GIF Symposium, and its second objective by the spring of 2019 at the EG/PG meetings. It also foresees the organization of an international workshop on the 'Needs for dedicated experimental facilities, and R&D infrastructure needs from industry and private start-ups' initiatives'. The TD supervises all activities of GIF RDTF and will make use of the EG to review for quality and completeness of all key outputs.

GIF RDTF takes advantage of GIF Member State's, IAEA's and NEA's relevant works, among others: a) R&D needs Outlook(s); b) R&D infrastructures, databases, reports, compendium, International Cooperation initiatives and collaborative projects (e.g. IAEA CRPs, ICERR, NEA joint projects, NEST, NI2050, and EU/EURATOM projects). [1] [2]

The Task Force benefits from GIF Member State's latest relevant updates together with:

- a) IAEA database of Facilities in Support of Liquid Metal-cooled Fast Neutron Systems Facilities, and its latest compendium;
- b) The Advanced Reactor Information System (ARIS);
- c) The Research Reactor database (RRDB);
- d) The OECD/NEA Research and test facilities database (RTFDB);
- e) The OECD/NEA Task Group on Advanced Experimental Facilities (TAREF) on SFR and GFR but also the Support Facilities for Existing and Advanced Reactors (SFEAR);
- and f) The EU/EURATOM projects' roadmap proposal for building knowledge and facilities needed for the development of nuclear energy systems such as ADRIANA (Advanced Reactor Initiative And Network Arrangement). [3]

An opportunity is also taken to propose any update of existing IAEA and NEA databases (including any new infrastructures or facilities launched) with the close support of GIF SSC (or pSSC) and EG groups. Upon completion of the two objectives of the GIF-RDTF, SSCs and pSSCs will be expected to maintain cognizance of infrastructure needs and approaches for their access as work evolves.

II. APPROACH

GIF RDTF identified the following technical areas to be addressed: a) Thermal-hydraulics; b) Fuel safety; c) Reactor physics; d) Severe accidents; e) Structural integrity, system components and validation; f) Coolant chemistry; g) Cross-cutting areas (instrumentation, ISI&R, E&T,...); and h) Any other issues.

With the benefit of TAREF and latest reports, elaboration of a PIRT-like (PIRT exercise = Phenomena Identification and Ranking Tables) was confirmed to be already available within GIF SSC's documentation. In general, the ranking tables of experimental facilities provide: a) A ranking of the issues to be investigated; b) A ranking of the facilities in connection with their capability to address each topic; and c) A ranking of the needed experimental infrastructures to be upgraded and/or constructed.

Safety (+ security) needs (challenges) requiring key research were based upon following criteria:

- a) Status of knowledge, Low (L), Medium (M), High (H);
- b) Design relevance (contribution of dedicated facilities to solve a design issue, L, M, H);
- c) Safety relevance (contribution of dedicated facilities to solve a safety issue, L, M, H);
- d) Operational relevance (contribution of dedicated facilities to solve an issue L, M, H);
- e) Implement a scheduling of the safety and security needs to iterate within the projects (Short term 0–2 years (H), medium term 2–5 years (M), long term > 5 years (L)).

Based on the information assembled on both safety (and security) challenges and related facilities, Task Force members assessed prospects and priorities for safety research and recommendations as priorities regarding facility utilization through multi-lateral and/or GIF cooperative programs.

The main CRITERIA FOR RANKING were:

- a) Technical relevance (relevance of the facility to cover a specific issue);
- b) Uniqueness (No alternative facility for the same goal, e.g. one of a kind for in-pile testing);
- c) Availability (Availability for a given identified program addressing the issue);
- d) Readiness (Facility / test section for the specific issue is available; staff available to run it);
- e) Construction (or refurbishment) costs (N/A, L: < 1 , M: 1–5, H: > 5 M\$, \$ = US Dollar);
- f) Operating costs (actual or estimated) (L: < 0.3 , M: 0.3–1, H: > 1 M\$/y);
- g) Experimental device costs (N/A, L: < 1 , M: 1–3, H: > 3 M\$);
- h) Flexibility (Capacity to be adapted to various areas thus ensuring good return of investment);
- i) Availability timeframe (Short term 0–2 years (H), medium term 2–5 years (M), long term > 5 years (L));
- j) Existence of preliminary schedule and refurbishment of the facility (Level of financial and scheduling elements related to the facility for the specific issue considered).

Based on the above characteristics, Generation-IV systems (SFR, LFR, GFR, VHTR, SCWR and MSR) major (or critical) experimental infrastructure (or facilities) needs in function of the respective R&D objectives for the next decade (i.e. viability, performance, or demonstration – depending on the

II. APPROACH

respective system TRL) are presented, based upon national R&D programs and considering industrial needs.

REFERENCES

- [1]: Generation-IV International Forum (GIF) <http://www.gen-4.org/>, International Atomic Energy Agency <http://www.iaea.org/>, OECD Nuclear Energy Agency <http://www.oecd-nea.org/>
- [2]: GIF Publications https://www.gen-4.org/gif/jcms/c_9373/publications GIF Technology Roadmap update, January 2014, <https://www.gen-4.org/gif/upload/docs/application/pdf/2014-03/gif-tru2014.pdf>
- GIF R&D Outlook, August 2009, https://www.gen-4.org/gif/upload/docs/application/pdf/201310/gif_rd_outlook_for_generation_iv_nuclear_energy_systems_2013-09-30_15-49-32_599.pdf, update October 2018, https://www.gen-4.org/gif/upload/docs/application/pdf/201906/7411_gif_r_and_d_outlook_update_web.pdf,
- IAEA Databases <https://www.iaea.org/resources/databases>
- OECD/NEA NI2050 initiative <https://www.oecd-nea.org/ndd/ni2050/>
- OECD/NEA NEST initiative <https://www.oecd-nea.org/science/next/>
- IAEA International Centres based on Research Reactors (ICERRs) <https://www.iaea.org/about/partnerships/international-centres-based-on-research-reactors-icerr>
- CORDIS, European Community Research and Development Information Service http://cordis.europa.eu/home_en.html
- [3]: IAEA database of Facilities in Support of Liquid Metal-cooled Fast Neutron Systems Facilities <https://nucleus.iaea.org/sites/lmfns/Pages/default.aspx>
- IAEA Advanced Reactor Information System (ARIS) <https://aris.iaea.org/>
- IAEA Research Reactor database (RRDB) <https://nucleus.iaea.org/RRDB/RR/ReactorSearch.aspx>
- OECD/NEA Research and test facilities database (RTFDB) <https://www.oecd-nea.org/rtfdb/>
- OECD/NEA Task Group on Advanced Experimental Facilities (TAREF) on SFR <https://www.oecd-nea.org/globalsearch/download.php?doc=77089> and GFR <https://www.oecd-nea.org/globalsearch/download.php?doc=8901>
- OECD/NEA Task Group on Support Facilities for Existing and Advanced Reactors (SFEAR), 2007, <https://www.oecd-nea.org/globalsearch/download.php?doc=6450>
- EU/Euratom project ADRIANA roadmap, 2010, https://cordis.europa.eu/docs/projects/files/249/249687/adriana-final-report_en.pdf

III. SFR R&D INFRASTRUCTURES

The Sodium-cooled Fast Reactor (SFR) uses liquid sodium as the reactor coolant enabling high power density, a fast neutron spectrum enabling fissile fuel regeneration and minor actinide management, and enhanced inherent and passive safety operating regimes. High outlet temperatures (500-550°C) and innovative capital cost-reducing R&D can provide an economically competitive case for SFRs in future electricity markets. Current plant options under consideration include pool and loop type primary systems and range from small modular reactors (50 to 300 MWe) to larger plants (up to 1500 MWe). Over 60 years of international SFR demonstration and operation programs (e.g., PHENIX, Joyo, EBR-II, BN800, etc.) have established much of the base SFR technology making it one of the nearest-term deployable Generation-IV systems.

Key R&D challenges for the GIF SFR System in the coming 10-15 years

- Advanced non-minor actinides bearing, minor actinides bearing, and high-burnup fuels evaluation, optimization and demonstration (cross cutting challenge for all fast neutron spectrum systems).
- Development of innovative In-Service Inspection and Repair (ISI&R) technologies.
- Advanced energy conversion systems.
- Development of Leak Before Break (LBB) assessment procedures and instrumentation.
- Development of steam generators including investigations of sodium-water reactions and development of advanced inspection technologies for a Rankine-type steam generator.
- Improved economics.
- Validation of passive decay heat removal.

Current international programs look to address remaining R&D challenges associated with SFR cost reduction, safety enhancement, development of mitigation Devices, demonstration of 60-years material life-time, in-service inspection, energy conversion systems, and advanced fuel development. The GIF SFR SSC maintains a list of key R&D areas necessary to drive SFRs to commercialization. Priority SFR R&D areas on the list include: inherent safety, severe accident mitigation, safety analysis tools, decommissioning experience, evaluation of advanced fuel options, high burn up fuels, fabrication of minor actinide fuels, demonstration of minor actinide recycle, monitoring instrumentation, in service inspection and repair, high temperature leak before break and defect inspection, fuel handling technology and strategy, energy conversion technology, advanced materials, nuclear data, advanced modelling and simulation, modelling code benchmarks (VV&Q), codes and standards, and advanced core design.

The SFR system is the most mature of all six GIF systems since it has already overcome the prototype phase. Consequently, the sodium infrastructures of main countries has slightly moved from test and component validation purpose to specific technological improvements. Moreover, due to the long term of international relationship between the sodium communities, the list of all sodium infrastructures is well known and usually updated. The IAEA is playing a key game in maintaining alive and refreshing every two years this facility list.

III. SFR R&D INFRASTRUCTURES

However, SFR SSC members currently maintain various experimental capabilities supporting key SFR R&D areas to enhance safety, improve the design or increase the system performance.

France capabilities include different kind of experimental facilities. Some of them are dedicated to sodium experiences, some others are versatile and respond to multipurpose needs. Among the dedicated experimental facilities handling liquid sodium, a few are located in CEA Paris-Saclay and most of them are located in CEA Cadarache site forming the PAPIRUS platform. Here are mentioned some of the most representatives:

- the CORRONa and TRIBONA facilities for short to long term materials static and dynamic corrosion testing in sodium including tribo-corrosion;
- the DIADEMO-Na facility for sodium components and instrumentation testing (e.g. sodium to gas heat exchanger testing up to 40 kWth, innovative valves or flowmeters testing);
- the DOLMEN facility which provides 600 and 1500 l. large pots of sodium at temperatures up to 600°C for under-sodium experiments instrumentation and in-sodium SFR components testing;
- the FUTUNA2 facility for qualification of sodium leak detection monitoring systems and for study of under insulating materials corrosion phenomena;
- the IRINA facility which provides 1085 l. of sodium up to 550°C for in-sodium small component and instrumentation testing;
- a set of sodium multipurpose glove boxes such as the LIQUIDUS one for studying the performance of ultrasonic transducers in sodium;
- the MECANA facility for mechanical testing of components in high purity sodium at prototypic temperatures;
- the PEMDYN facility to study magneto-hydrodynamic sodium pump performance;
- the SUPERFENNEC sodium handling training facility.

Some facilities uses water as simulant but are dedicated to SFRs such as the BACCARA facility that studies sodium hydrodynamic behavior around test fuel assemblies, or the PLATEAU facility for qualifying hydrodynamic performance of various components with specific SFRs geometries. Some other facilities handle non liquid sodium but solid state sodium to develop and qualify process used in the field of maintenance or dismantling such as the CARNAC and SCORPION/ENCRINE facilities to study different sodium / chemical treatment prior to removal or repair of the components or structures.

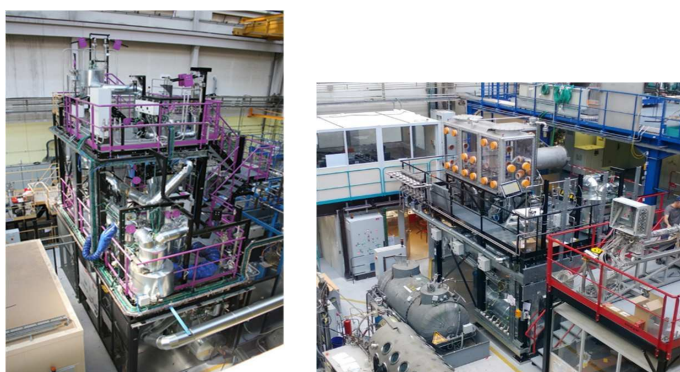

Figure III-1: Left: the DIADEMO Facility dedicated to the performance test of the sodium / gas Heat Exchanger in a Brayton cycle (CEA/CADARACHE – France). Right: the MECANA facility

III. SFR R&D INFRASTRUCTURES

South Korea capabilities include the STELLA-1 facility which consists of large sodium loops at 600°C and 2.5 MWth for large-scale prototypic sodium-to-sodium and sodium-to-air heat exchanger development supporting passive SFR safety systems; the SELFA facility to test thermal-hydraulic performance of finned-tube sodium-to-air heat exchangers at 600 °C and 700 kW; the HyTel-SF facility for full size fuel assembly hydraulic testing using water as a sodium surrogate; the PRESCO facility to develop core hydraulic performance parameters for PGSFR safety analysis; the CRDM-SPITF facility for control rod drive system performance testing; and the SOFUS facility to conduct performance tests of under-sodium ultrasonic sensors in a sodium environment.

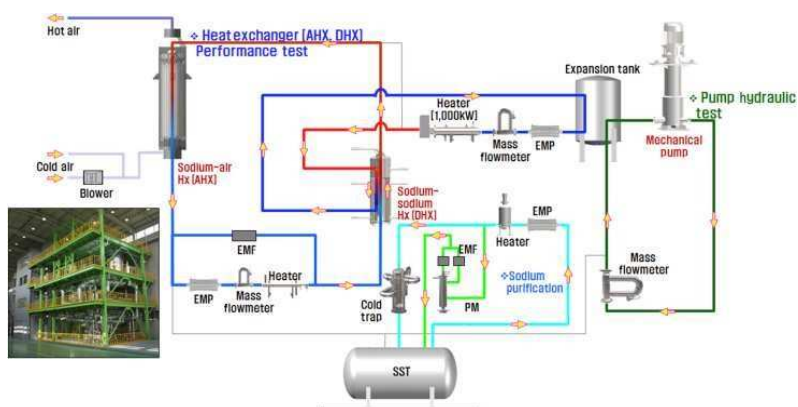

Figure III-2: Sodium Test Loop for Safety Simulation and Assessment-1 test facility. AHX, air heat exchanger; DHX, decay heat exchanger; EMF, electromagnetic flowmeter; EMP, electromagnetic pump; PM, plugging meter; SST, sodium storage tank (KAERI – Dejon – Republic Of Korea)

United States capabilities include the METL facility which consists of prototypic sodium environment loops for intermediate-scale SFR component, instrumentation, and material testing; the SNAKE facility for studying sodium-SCO₂ interactions to support SCO₂ energy conversion system development; the Advanced Test Reactor test for thermal spectrum irradiations; the TREAT reactor to study the performance of fast reactor fuels during transients; hot fuel examination facilities at the Idaho National Laboratory supporting post irradiation examination; the NSTF facility for testing SFR passive safety system performance; in-sodium materials testing loops at the national laboratories; and advanced fast reactor modelling and simulation suites.



Figure III-3: The ESFR Network of European sodium facility in the frame of the ESFR-Smart Project

III. SFR R&D INFRASTRUCTURES

Euratom capabilities include the KASOLA facility to investigate variable flow phenomena in liquid sodium at temperatures from 150-550°C; the ALINA and NATAN facilities for lower temperature in-sodium thermal-hydraulics, materials, and instrumentation testing; the DRESHDYN facility which consists of 12 tons of sodium for large scale experimental studies of magneto-rotational instabilities and single and two phase sodium flow for SFR safety evaluations; the SOLTEC facility which can be used for thermal-hydraulics, coolant chemistry, materials, systems and components, instrumentation, and design basis accident testing and analyses for licensing validation and verification purposes; the TESLA facility for in-sodium testing of components and instrumentation; and the STL300 facility for high-temperature liquid metal thermal-hydraulic performance testing.

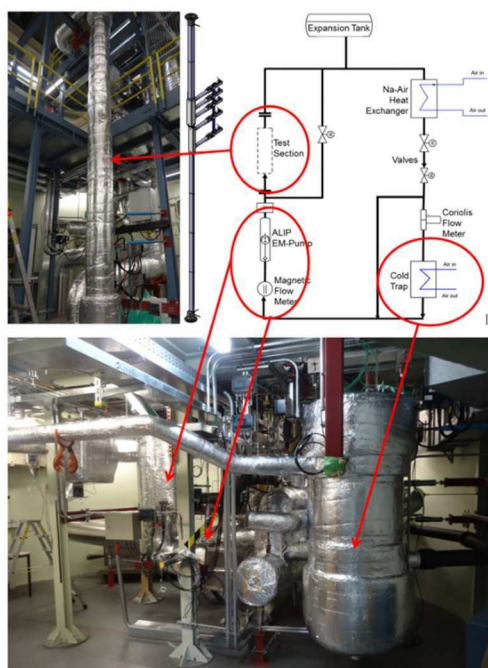

Figure III-4: The KASOLA facility at KIT, Germany

China capabilities include sodium test loops supporting SFR safety analysis and high temperature material and component testing; the China Experimental Fast Reactor (CEFR) that will provide SFR oxide fuel performance, inherent safety, passive decay heat removal, instrumentation, and operational benchmark data; SFR natural circulation testing facility; sodium-SCO₂ interaction facility; and SCO₂ thermal-hydraulic performance and sodium-SCO₂ heat exchanger performance testing experiments.

Japan capabilities include the AtheNa facility for large scale component and system sodium test with 60MW heat capacity; the PLANDTL facility for sodium thermal-hydraulic transient testing; the CCTL facility for subassembly and component sodium testing; the SWAT facility for sodium water reaction testing; test loop to explore the effects of sodium on material fatigue; the FRAT facility for sodium fire testing; the MELT facility to explore molten fuel behavior; the SERF facility for in-service inspection component development; and the experimental fast reactor Joyo for fast flux irradiation.

III. SFR R&D INFRASTRUCTURES

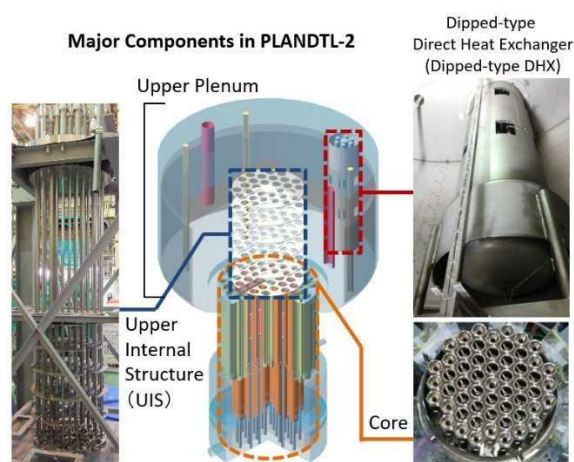

Figure III-5: The PLANDTL-2 facility at O Arai, Japan

The UK can support modelling and simulation (using historic UK and international data). Fuel cycle research can be carried out in the UK, at a single plutonium active or separate uranium active facility. On waste management R&D, the UK has the experience to manage wastes arising from the operation and decommissioning of SFRs. A sodium loop rig is being developed but is currently only at design stage.

Russian capabilities include a number of experimental facilities that allow research in coolant technology and testing small equipment, as well as operation of large equipment and conducting irradiation tests. The State Scientific Center Institute of Physics and Power Engineering (IPPE) in Obninsk possesses significant R&D infrastructure capable to support the development of liquid metal cooled fast reactors. A list of IPPE facilities for thermal hydraulic research with water and liquid metal includes V-200 (water), PLUTON (Na), 6B (Na, Na-K), AR-1 (Na, Na-K), SPRUT (Na, Na-K, Pb, PbBi), IRS-M (Na). Sodium technology research is performed at PROTVA-1 (Na, Na-K), PROTVA-2 (Na), SID (Na, Na-K), VTS (Na) facilities.



Figure III-6: SFR 6B Sodium Hall facility at IPPE (Russia)

Research of the sodium-water reaction in steam generators and testing of large size equipment is performed at SAZ (Na) facility. The isothermal facility SAZ is a full-scale mockup of piping systems and equipment of the steam generator section used at the BN-800 reactor and can be used to study automatic protection systems for sodium-water steam generators. The facility includes main and auxiliary sodium loops; water-steam circuit; gas-vacuum circuit; distillate preparation system; facility control panel; measuring and computing system, etc. Technical characteristics of the facility are the

III. SFR R&D INFRASTRUCTURES

following: sodium flow rate in the primary loop – 1200 m³/h; pump pressure – 0.9 MPa; maximum sodium temperature – 510°C; sodium volume – 25 m³, electric power – 3 MW.

The BFS-1 and BFS-2 critical facilities (BFS stands for Big Physical Facility) are designed for full-scale modeling of fast-reactor cores, blankets, in-vessel shielding, and storage, as well as for obtaining additional neutron-physics information necessary for the design of fast reactors. The core volume can be varied from tens of liters to six cubic meters.



Figure III-7: BFS-1 and BFS-2 facilities at IPPE (Obninsk, Russia)

The State Scientific Center RIAR (Dimitrovgrad) is the leading organization in Russia for the irradiation tests in support of R&D for fast reactors. Nowadays these tests are performed at the experimental fast neutron reactor BOR-60, and its experimental capabilities are well known in the world. BOR-60 allows carrying out following studies: fuel cladding tests, fuel material tests (MOX, nitride), reactor tests of absorbing materials, reactor tests of structural materials.

There is a new research reactor MBIR under construction in RIAR. It will substitute the BOR60, which operation life is limited by December 2025. MBIR is a multipurpose fast neutron research reactor that is going to be the world leader among high flux research facilities. Its unique physical characteristics are best suited for material science experiments, e.g. testing innovative fuel and new coolants, and entire infrastructure required for in-pile research will be available. The first experiment in MBIR is planned in 2025. Preliminary characteristic of in-core irradiation loops are given below.

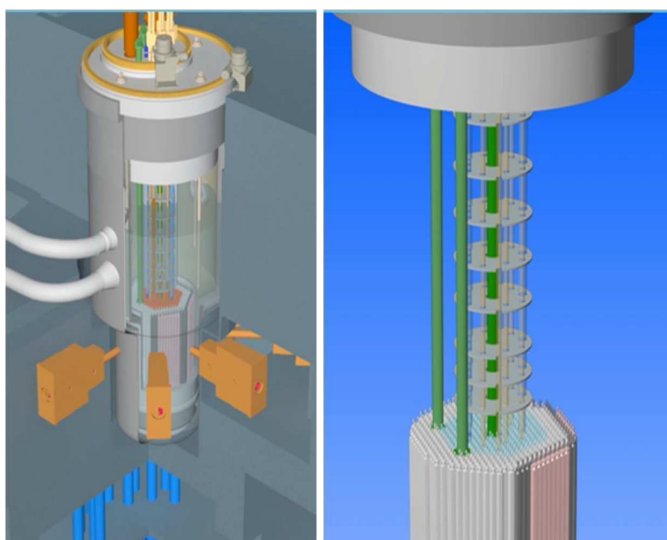

III. SFR R&D INFRASTRUCTURES

Loop type (coolant)	Sodium	Lead	Lead-bismuth alloy	Gas (high purity helium)	Molten salt (metal fluorides)
Neutron flux in channel, (n) cm ⁻² ·s ⁻¹	≥ 3·10 ¹⁵	2·10 ¹⁵	(2÷3)·10 ¹⁵	(0.4÷1)·10 ¹⁵	Up to 3.5·10 ¹⁵
Power, MW	Up to 1.0	≥ 0.3	Up to 0.8	Up to 0.15	Up to 0.15
Tin/Tout of working fluid, °C	320 / 550	Up to 350 / up to 750	Up to 350 / up to 500	/ ≥ 950	750 / 800

Figure III-8: MBIR, its irradiation channels and experimental loops and main characteristics at IPPE (Dmitrovgrad, Russia)

While current global experimental infrastructure exists to address some SFR R&D needs, the SFR SSC has identified key experimental and analytical infrastructure gaps. For SFR advanced fuel and material qualification, worldwide fast neutron irradiation capability is largely lacking. Current water-cooled materials test reactors (MTRs) produce damage rates of approximately 10 dpa/yr. To attain peak doses typical of advanced fast reactors (200 to 500 dpa), a water-cooled MTRs would take 20 to 50 years. Fast neutron irradiation capabilities provide the high fast to thermal neutron flux ratio that is needed to develop fast spectrum systems and to accelerate materials irradiations needed for both thermal and fast reactors. The SFR SSC has identified several key characteristics for future fast spectrum irradiation capabilities including: multiple irradiation volumes and lengths, provisions to test prototypic and bounding conditions, sufficient number of test zones, distinct and independent irradiation test loops, ability to retrieve specimen at power, and ability to support secondary missions. These features could significantly reduce timelines for fast reactor fuel and materials qualification and performance testing allowing SFRs to more quickly enter the market.

In the area of safety analysis, SFR SSC members identified the need for integral effects experimental facilities supporting comprehensive SFR system transient behaviour and safety analysis. Decay heat removal test facilities to further optimize SFR passive safety systems was identified as a priority need. The SFR SSC also identified the need for testing facilities to explore the performance of innovative control rod safety systems. Continued benchmarks on legacy SFR transient behaviour tests and facilities to provide test data to optimize SFR natural circulation models were also identified as SFR safety case development needs. SFR SSC members also identified the need for particle/aerosol tracing facilities and enhanced sodium-water interaction tests to support SFR mechanistic source term activities. For severe accidents studies, it was identified that some facilities are needed for sodium/corium interaction and for qualification of associated mitigation technical solutions. The SFR SSC members also identified a need for continued studies related to the implementation of probabilistic assessment techniques on postulated external events for SFRs. Members also identified the need for an in-sodium seismic performance test loop/facility. For SFR component testing, SFR SSC members identified the need for large scale component in-sodium testing capabilities. These capabilities could support fuel assembly thermal-hydraulic testing, innovative fuel handling mechanisms testing, and heat exchanger performance testing. For in-service inspection, SFR SSC members identified the need for larger test sections to accommodate prototypic under-sodium ultrasonic sensor performance tests associated with a dedicated carrier (robotic arm for example). For advanced energy conversion, SFR SSC members identified the need for increased sodium – SCO₂ interaction and heat exchanger testing capabilities (mainly at large scale) to support the potential use of SCO₂ Brayton Cycles in SFRs.

III. SFR R&D INFRASTRUCTURES

SFR SSC member nations look to address some of these infrastructure gaps through a combination of modified and new facilities and potential facility sharing among members. The GIF R&D Infrastructure Task Force currently aims to assist member nations in identifying access pathways to international capabilities; and potentially developing international facility use access mechanisms within GIF.

REFERENCES

- [1]: O. Gastaldi et al., "Experimental platforms in support of the ASTRID program: existing and planned facilities", *Proc. of ICAPP 2015, May 03-06, 2015 - Nice (France)*.
- [2]: J.-B. Kim et al., "On the Safety and Performance Demonstration Tests of Prototype Gen-IV Sodium-Cooled Fast Reactor and Validation and Verification of Computational Codes", *Nuclear Engineering and Technology Vol. 48 (2016) 1083 – 1095*.
- [3]: K. Mikityuk et al., "ESFR-SMART: new Horizon-2020 project on SFR safety", *Proc of FR17, International Conference on Fast Reactors and Related Fuel Cycles, 26 – 29 June 2017, Yekaterinburg, (Russian Federation)*.
- [4]: F. Belloni et al., "A roadmap for European experimental research for Generation-IV reactor severe accident research", *Proc. of ICAPP 2019, May 12-16, 2019 – Juan les Pins, (France)*.
- [5]: H. Kamide et al., "Progress of design and related researches of sodium-cooled fast reactor in Japan", *Proc of FR17, International Conference on Fast Reactors and Related Fuel Cycles, 26 – 29 June 2017, Yekaterinburg, (Russian Federation)*.

IV. LFR R&D INFRASTRUCTURES

The Lead Fast Reactor (LFR) features a fast-neutron spectrum and a closed fuel cycle for efficient utilization of the energy value of fertile uranium and consumption of accumulated transuranic elements, thus minimizing the volume and radiotoxicity of long-lived, high level waste. One of the most important features of the LFR is the enhanced safety that results from favourable basic and intrinsic characteristics of lead as primary coolant. Lead features high boiling point (1749°C), which provides the ability to operate the reactor at close to atmospheric pressure. Lead is at the same time relatively inert in contact with air and water, featuring also high thermal inertia and natural convection capability for enhanced passive safety. LFRs have the potential to be deployed for large grid-connected power stations as well as to meet the electricity needs of remote sites as small modular reactors.

Key R&D challenges for the GIF LFR System in the coming 10-15 years

- Phenomenology of the lead-water and lead- steam interactions.
- Prevention and mitigation of sloshing.
- New corrosion resistant materials (including surface modifications).
- Operation and maintenance.
- Fuel and fuel reprocessing (nitride, minor actinides bearing, and high burn-up fuels).
- Advanced modelling and simulation.
- Design Code and Standards.
- Severe accidents.
- Progress towards the deployment of a Gen-IV LFR (BREST-OD-300).

LFR is considered a very promising Generation-IV reactor since it is expected to naturally comply with and fulfil the GIF goals: (i) sustainability, through the use of a closed fuel cycle possible for a Fast Reactor; (ii) a robust and improved safety performance benefitting from the intrinsic characteristics of the coolant; (iii) favorable economics, in particular due to design simplifications and high secondary cycle thermodynamic efficiency; and (iv) bringing also substantial advantages in terms of proliferation resistance and physical protection. LFRs require on the other hand additional development in a number of technical areas before reaching a full industrial maturity although the already available technology is considered sufficient to start the construction of a demonstrator, an essential step before realization of a First of a Kind (FOAK).

In terms of the availability of R&D infrastructures and facilities, the LFR presents a rather well developed situation. This is a result of the efforts made since the beginning of GIF activities related to LFR systems as well as parallel activities concerning the use of heavy liquid metal coolants for Accelerator Driven Systems (ADS), complemented recently by a strong interest in the field of fusion technology development. A number of facilities, infrastructures, equipment and experimental set-ups are presently available and are generating data dedicated to the priority areas related to the technology development and qualification.

EXISTING KEY INFRASTRUCTURES

The majority of information on such facilities is efficiently collected in the IAEA liquid metal database, the so called LMFNS Catalogue (Catalogue of Facilities in Support of Liquid Metal-cooled Fast Neutron Systems, <https://nucleus.iaea.org/sites/lmfns/Pages/overviewlfr.aspx>), which is collecting also

IV. LFR R&D INFRASTRUCTURES

the information related to facilities supporting the development of SFRs¹. The review of the database data reveals that, in terms of the number of facilities, the situation for LFRs is comparable to that for SFRs. Efforts are presently carried out by IAEA to keep this database updated and complemented in terms of status, availability of and access to experimental data, as well as availability of the infrastructures to host dedicated experiments. Representatives of the GIF members may solicit owners and operators of the facilities in order to keep the IAEA LMFNS Catalogue up-to-date.

Considering the contributions provided by the individual GIF members, one may observe a prevalence of facilities dedicated to investigations of the interaction of materials with coolant (including corrosion-erosion and material mechanical properties), thermal hydraulics, and integral system studies. A number of facilities dedicated to neutronics and core simulations are available.

The contributions of the individual GIF members are listed below (in an alphabetical order).

BELGIUM

Facilities in Belgium are mainly located at the SCK•CEN Research Centre in Mol. Most of them are dedicated to studies of thermal hydraulic behaviour and corrosion in liquid lead-bismuth eutectic (LBE). SCK•CEN also operates a unique zero power facility (VENUS-F) that has been used for nuclear data generation in several collaborative projects co-financed by EU / EURATOM.

Most of the facilities and studies have been dedicated to the advancement of the coolant technology for the MYRRHA project – a multifunctional research and irradiation facility as well as demonstrator of the ADS technology. In 2018, the Belgium Federal Government has decided to invest 558 M€ in the realisation of MYRRHA. This also includes the construction of a 100 MeV accelerator as a first step towards the implementation of the MYRRHA project.

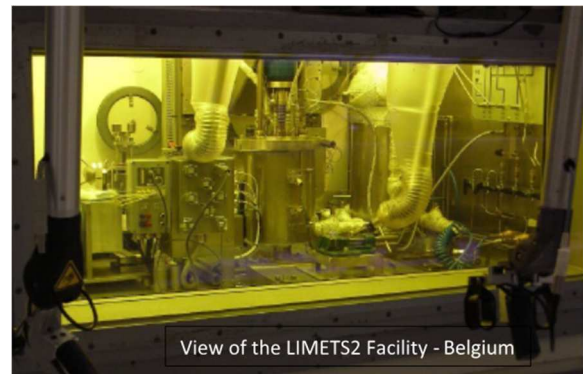

Figure IV-1: The LIMETS2 facility (SCK-CEN, Belgium)

CZECH REPUBLIC

Facilities related to heavy-liquid metals (HLM) have been developed in CVR (in Řež near Prague), historically on the basis of Russian experience (COLONRI, presently dismantled) deploying loops for natural circulation studies in both LBE and pure lead coolants. A number of new facilities have been realized as a part of the Sustainable Energy Project (SUSEN) which was co-funded by the EU and which supports the development of the Generation-IV as well as fusion technologies.

¹ In the LMFNS Catalogue (<https://nucleus.iaea.org/sites/lmfns/Pages/overviewlfr.aspx>) some facilities are classified as cross-cutting, which means that they can be used for general development and qualification of the liquid metal cooled systems.

IV. LFR R&D INFRASTRUCTURES

EURATOM, Joint Research Centre (JRC)

JRC Petten has recently commissioned an experimental facility (LILLA) for conducting prenormative mechanical tests of candidate structural materials for LFRs inside realistic environmental conditions of molten lead in temperatures up to 650°C.

Efforts are presently also ongoing to create a database of experimental data to improve understanding of the involved degradation mechanisms and to update Design Codes and Rules for the design of mechanical components of LFRs. Moreover, fundamental safety-related studies of fuel-coolant interactions as well as fission and activation product retention in HLM are ongoing at JRC Karlsruhe.



Figure IV-2: The LILLA facility (JRC Petten, NL)

FRANCE

Although France has historically been dedicating its efforts to the development of sodium technology, some experiments have already been performed to investigate corrosion in HLM.

GERMANY

Karlsruhe Institute of Technology (KIT) has been active in research on HLM technology since the mid-1990s, in which period also the first EU-funded projects were launched. Most of the available facilities are dedicated to investigations of the material compatibility with HLM and coolant chemistry. Several thermal hydraulic loops have been realized at KIT as well.

Important R&D efforts are also conducted by the Helmholtz-Zentrum Dresden-Rossendorf (HZDR), specifically as regards the development and qualification of electromagnetic pumps as well as measuring techniques for heavy liquid metals. It is noted that the HZDR facilities are currently not documented in the IAEA database.



Figure IV-3: The THEADES facility (KIT, Germany)

ITALY

A very well-known and established location for the HLM R&D activities is the Brasimone Research Centre of ENEA (located on the shore of the Brasimone Lake close to Bologna). The Centre, originally built in the 1980s to conduct research on fuel assembly qualification for SFRs, is currently hosting a large experimental base for HLM technology development. This includes facilities with LBE, pure lead and lithium-lead, the latter dedicated to the development of fusion applications. The ENEA Brasimone Centre has been active in the field of the HLM technology development for around 20 years, since the late 1990s until present. One of the largest integral facilities is hosted in the Centre – a pool of LBE with a diameter of 1 m and a height of 9 m. Several other installations are dedicated to investigations of the natural and forced circulation flow, coolant chemistry, corrosion, etc. The Centre is strongly supporting the technological development of the European LFR demonstrator ALFRED.

IV. LFR R&D INFRASTRUCTURES



Figure IV-4: The CIRCE SGTR test section (ENEA Brasimone, Italy)

JAPAN

Several facilities are documented in the IAEA database. These are operated by JAEA in support to the development of transmutation systems and related LBE technology. Japan has historically also been the first signatory (together with EURATOM) of the GIF-LFR-MoU, providing important R&D contributions to the HLM technology. This includes investigations of the material corrosion resistance, oxygen control, and oxide layer thickness. The latter work is conducted by the Tokyo Institute of Technology as a part of its contribution to LFR-pSSC activities.

REPUBLIC OF KOREA

R&D activities and facilities in Korea have historically been centred at Seoul National University (SNU). These activities are currently being broadened to other potentially interested Universities in the Country. Numerical benchmarks like LACANES (in the frame of OECD-NEA) have been proposed and carried out by SNU. Some recent experimental facilities realized at SNU, like PILLAR, are not yet documented in the IAEA database.

LATVIA

The activities in Latvia have historically been interlinked with the development of electromagnetic pumps, which were realized in several loop installations. Although only one facility is reported in the IAEA database, it is well recognized in the HLM community that an important contribution has been provided by Latvian researchers in this field.

PEOPLE'S REPUBLIC OF CHINA

In China, the R&D activities on HLM technology are being conducted mainly in the context of the development of an ADS transmuter.

IV. LFR R&D INFRASTRUCTURES

Several facilities have been realized by Institute of Nuclear Energy Safety Technology (INEST) of the Chinese Academy of Sciences in Hefei (Anhui Province). Presently the largest HLM pool-type facility (CLEAR-S) has been deployed and is in operation at INEST. The interest in the HLM technology is rising in the Country, including from several industrial research centers. This is expected to further accelerate the development of the HLM technologies in China.



Figure IV-5: The KYLIN-II M facility (China)

RUSSIAN FEDERATION

Russia is undoubtedly the most advanced Country in the development of heavy liquid metal technology, starting in the early 1960s with the deployment of LBE-cooled nuclear reactors for defence (submarine propulsion) applications.



Figure IV-6: The BSF-1 facility (IPPE Obninsk, Russia)

Several experimental facilities are listed in the IAEA database related to the most relevant technological aspects of the HLM technology. Of particular interest are also the BFS facilities (cross cutting) allowing the simulation of a full core neutronic behaviour, providing thus an insight into the intrinsic characteristics of the reactor core. Mixed nitride fuel is used for BREST-OD-300, for which purpose individual pins and fuel assemblies are being qualified in-pile in BOR-60 as well as BN-600. The realization of BREST-OD-300 demonstrator will provide an essential contribution to the advancement of the technological capabilities of the Russian Federation.

SPAIN

Spain and specifically the CIEMAT Research Centre (in Madrid) has been active in the development of the HLM technology, participating in most of the EU co-funded projects dedicated to HLM technology since the mid-1990s. The Centre dedicates its efforts to the evaluation of the material interactions with HLM coolants, which includes studies of corrosion behavior and material mechanical properties as well as oxygen and chemistry control of the coolant.

IV. LFR R&D INFRASTRUCTURES

SWEDEN

KTH Royal Institute of Technology in Stockholm has been one of the main partners in the HLM development in Europe since the mid-1990s. Although only one facility is reported in the IAEA database (TALL-3D), the installation has provided important experimental data used in international benchmarks. Activities at KTH have also resulted in some important industrial spin-off projects. Other activities at the Chalmers University of Technology and KTH may be considered as cross-cutting, since they are mainly devoted to the development and characterization of nitride fuels.

U.K.

Fuel cycle research can be carried out in the UK, at a single plutonium active or separate uranium active Facility.

UNITED STATES OF AMERICA

In US, the R&D activities related to the HLM technology have historically been impacted by difficulties encountered in the late 1950s in the control of corrosion in HLMS. However, in the recent years some new experimental facilities have been realized. There is also a renewed interest in HLM technologies from industry and academia. US signed the GIF LFR MoU in 2018, which is expected to generate further interest in and provide impetus to the development and deployment of this technology in US.

Following the review of the state-of-the-art concerning the availability of individual infrastructures and facilities in the individual GIF members, as also documented in the IAEA LMFNS database, needs for additional infrastructures and experimental capabilities to support development and deployment of the HLM technologies are listed and discussed below.

IDENTIFICATION OF ESSENTIAL GIF R&D INFRASTRUCTURES FOR GENERATION-IV LFRS

The main R&D objectives for the development of the LFRs were identified in the 2014 Technology Roadmap Update for Generation-IV Nuclear Energy Systems and 2018 GIF R&D Outlook report as follows:

- materials corrosion-erosion and lead chemistry;
- material irradiation in the lead coolant environment;
- core instrumentation;
- fuel handling technology and operation;
- fuel development (MOX and nitrides);
- actinide management;
- fuel reprocessing and manufacturing;
- in-service inspections and repair (ISI&R);
- seismic impact mitigation (including sloshing);
- phenomenology of lead-water/steam interactions;
- fuel-coolant interactions, incl. retention of radioactive products in lead;
- and general severe accident phenomenology and modelling.

Although the aforementioned list of needs can be considered as long and rather generic, most of those needs can be satisfied by the existing experimental infrastructures and facilities, provided they remain in operation and are made available to the HLM community. However, there are some specific

IV. LFR R&D INFRASTRUCTURES

needs in terms of experimental R&D infrastructures, which are not yet covered by the existing installations. These facilities and infrastructures essential to further development and deployment of the GIF LFR technologies is given below.

Large pool-type experimental installations

Most of the facilities already existing and operational are of small scale and have loop type configurations. At the same time, a considerable number of facilities use Lead Bismuth Eutectic (LBE) instead of pure lead for which the behavior (in terms of material corrosion-erosion and other degradation mechanisms) may be different. At the same time, operational characteristics of LBE and Pb are also different, in particular due to higher minimum operational temperature associated with pure lead.

As most of the LFR designs are featuring pool-type integral configuration, there is a strong need to set up a research infrastructure of relatively large dimensions (preferably with pure lead) that can serve the following fundamental purposes:

- testing and qualification of full-size components and appropriately scaled configurations of the primary system of the GIF LFR designs;
- investigation of oxygen behavior, distribution, and qualification of its control in a very large pool configurations;
- investigation of sloshing phenomena on an adequately representative scale;
- investigation and qualification of technical solutions for fuel handling, operation and maintenance (as well as ISI&R);
- and investigation of the phenomenology of lead/water interaction on a representative scale.

The construction of such a large facility would be an important milestone, bringing a significant added value to the development of the LFR technology and providing a fundamental support towards the deployment of a LFR demonstrator/pilot plant.

Fuel manufacturing & reprocessing

The implementation of Fast Reactors in a closed fuel cycle is based on a concerted development and qualification of the reactor technology as well as of fuel manufacturing and reprocessing technologies. While in the Russian Federation, the latter needs have been addressed in a timely manner (with the development of nitride fuels which qualification is currently ongoing), there seems to be a lack of coherent and adequate efforts for such developments in other Countries. To develop qualified fuel manufacturing and reprocessing capabilities (either based on MOX or MNUP) for irradiated (minor actinide bearing) fuels needs an adequate investment to relevant experimental facilities to assess these technologies, before advancing to industrial-scale installations.

Irradiation capability

There is an evident lack of available irradiation facilities, which hinders the development and qualification of new structural materials, fuels and/or other innovative technological solutions due to the long time and associated costs needed for performing these irradiations in currently available facilities.

Experimental facilities performing heavy ion irradiations may become in some cases a good substitute for neutron irradiation facilities, as they allow attaining high dpa's in a relatively short period of time. This approach, however, necessitates further development and qualification of an adequate

IV. LFR R&D INFRASTRUCTURES

“equivalence law” between heavy ion irradiations and neutron irradiation. In any case, the qualification of new, advanced materials for FRs is strongly limited by the general lack of fast neutron spectrum irradiation facilities (including in the representative coolant environments). These facilities are also necessary for further development of Design Codes and Standards for the design of mechanical components of LFRs.

This bottleneck may largely be rectified once the first demonstrator (pilot plant) of the LFR technology becomes available. Also for this reason, the realization of the LFR demonstrator is considered of a paramount importance for possible future international and industrial deployment of the LFR technology.

Retention of radioactive products in lead (including polonium)

One of the inherent advantages of lead is its capability to retain radioactive products. In fact, lead provides a relatively good capacity for retention of important volatile fission products as well as activation products. A large body of literature on the chemical and thermo-physical properties of lead and its compounds with cesium, strontium, iodine as well as polonium is available and give indications of relatively good retention properties of these nuclides in lead (e.g., volatilized fractions at 700°C for ¹³⁷Cs, ⁹⁰Sr, and ¹³¹I are 1.1×10^{-6} , 5.1×10^{-14} and 3.7×10^{-6} , respectively). Nevertheless, further R&D studies are necessary to assess the corresponding retention capabilities in order to evaluate related occupational hazards and possible accidental source terms. A specific case is represented by polonium, which is mostly retained in the lead bulk in the form of lead-polonide but may be released (extracted) from the lead bulk by the ingress of water (steam). Dedicated experimental facilities are needed to address these R&D topics representatively.

Severe accidents

Analyses of the GIF LFR designs performed according to the established safety approaches in the design extension domains have up to now not identified accident sequences which would lead to generalized core meltdowns. The assessments rather predict self-limitation of the core damage to a limited number of pins and fuel assemblies. However, until now, severe accident assessments have been performed mostly only analytically, with only incomplete experimental database available to support and validate the results of the computer simulations.

Consequently, a number of experimental facilities need to be set up to allow comprehensive investigations of the severe accident phenomenology, in support to ultimate safety demonstration.

LFR Demonstrator

The realization of an LFR demonstrator (pilot plant) is considered to be of a paramount importance for the development of the LFR technology. This will allow addressing most of the technological development needs, in addition to providing a test platform to investigate the feasibility and find practical technical solutions. This will also stimulate further research and development, allowing bringing the LFR technology to an increased level of maturity and readiness needed for the industrial deployment.

V. GFR R&D INFRASTRUCTURES

Key R&D challenges for the GIF GFR System in the coming 10-15 years

- Finalizing the design and initiating the licensing process of the GFR experimental reactor ALLEGRO.
- Qualification of the mixed oxide fuel adapted to the specific operating conditions of the ALLEGRO start-up core.
- Development (i.e. material characterization under normal and accidental conditions for fresh and irradiated fuel, qualification, and fabrication capacities) of dense fuel elements capable of withstanding very high temperature transients (i.e. carbide fuel with composite SiC and fiber reinforced SiC clad).
- Validation studies (codes and data): need of specific experiments addressing the innovative ceramic materials, as well as unique GFR specific abnormal operating conditions like depressurization and steam ingress.
- Air and helium tests on subassembly mock-ups under representative temperature and pressure conditions are necessary to assess the heat transfer and pressure drop uncertainties for the specific GFR design.
- Large-scale air and helium tests to demonstrate the passive decay heat removal function will be required for the ALLEGRO licensing process.
- GFR specific components (e.g. blowers and turbo machines, thermal barriers, etc.) development and qualification.

The GFR is a promising and attractive Gen-IV concept, combining the benefits of a fast spectrum and of a high temperature ($\sim 850^{\circ}\text{C}$ at the core outlet). The reference design is a pressurized (7 MPa) helium cooled reactor. The concept is clearly innovative compared to other reactor concepts and no demonstrator has ever been built. The project of an industrial GFR has to address key R&D challenges, especially regarding, the fuel technology, core performance and safety, in particular the decay heat removal (DHR) issue.

The ALLEGRO experimental reactor

The viability of the GFR technology shall be demonstrated by designing, constructing and operating the 75 MWth ALLEGRO experimental reactor (Table 1). ALLEGRO, would be the first ever Gas cooled Fast Reactor to be constructed. The objectives of ALLEGRO are to demonstrate the viability and to qualify specific GFR technologies such as fuel, the fuel elements and specific safety systems, in particular, the decay heat removal function, together with demonstration that these features can be integrated successfully into a representative system.

Nominal thermal power	75 MW		
Nominal electric power	0 MW	Core outlet temperature	530 °C
Start-up core fuel	Oxide	Primary pressure	7 MPa
Experimental positions in the core	6	Secondary coolant	Water

V. GFR R&D INFRASTRUCTURES

Long term fuel	Carbide	Number of secondary loops	2
Primary coolant	Helium	DHR systems coolant	Helium
Number of primary loops	2	Number of DHR systems (to the primary vessel)	3
Core inlet temperature	260 °C		

Table V-1: ALLEGRO main characteristics

ALLEGRO shall be used not only for technology demonstration but also for the qualification of innovative components, first of all the ceramic fuel (UPuC pellets in SiC-SiCf cladding). The DHR systems are being designed to operate at least partially under passive mode (natural convection) in depressurized conditions.

Looking ahead to the next 10-20 years, the GFR system will conclude the viability phase, enter the performance phase and most likely initiate the demonstration phase. The following major steps in GFR development are expected:

- The finalization of the design of a small experimental reactor ALLEGRO.
- The decision on launching the licensing process for the experimental reactor.

Thermal hydraulics

In support to the design and the corresponding safety assessment, experimental data from helium facilities are needed for the validation of thermal-hydraulic system codes. In addition, experimental programs are needed for the development of the GFR related instrumentation, gas purification and tightness, tribology, high temperature materials and thermal isolations as well as specific components.

As mentioned before, the DHR is a key issue to demonstrate the feasibility of the GFR and its experimental first step ALLEGRO. Two facilities were built recently and will be used in support to such demonstration, the S-ALLEGRO loop (Figure 2), located in Plzeň in Czech Republic owned and operated by the Research Centre Řež and the STU Helium loop (Figure 3), located in Trnava, Slovakia, operated by the Slovak University of Technology in Bratislava Faculty of Mechanical Engineering.



Figure V-1: S-ALLEGRO loop



Figure V-2: STU Helium loop

CEA performed experimental programs in He loops like HEDYT.



Figure V-3: HEDYT Helium loop

Coaxial pipes where hot Helium circulates in the inner pipe and the cold in the outer is one specific design feature of GFRs. Consequently, transients where the coolant bypasses the core due to an inner pipe rupture, plays a pivotal role in the design process. Further experiments are proposed in the near future to select the worst-case bypass configuration. In order to achieve this goal, first a small experimental mock-up is proposed using air working fluid. If the results of this mock-up reveal the need of further investigations, a larger experimental test facility is envisaged using helium working fluid.

Fuel

The development of an acceptable fuel system that meets the target criteria (viz. 1000°C normal operation clad temperature, no fission product release at 1600°C clad temperature during a few hours, and maintaining the core-cooling capability up to 2000°C clad temperature) is a key viability issue for the GFR system. It is necessary to develop an initial cladding material that meets the core specifications in terms of length, diameter, surface roughness, apparent ductility, level of leak tightness (including the potential need of a metallic liner on the clad), compatibility with helium coolant (plus impurities), and the anticipated irradiation conditions. The needs include fabrication capacities and material characterization under normal and accidental conditions for fresh and irradiated fuel.

The specific operating conditions of the ALLEGRO oxide fuel pins (viz. maximum fuel temperature below 1000°C, linear pin power below 100 W/cm) needs to be modelled. The FUROMFBR Code has been developed in Hungary and its validation is a medium term task. The results of such codes are very sensitive to fission gas release predictions. In this context, a program of post-irradiation examinations on selected pins of the in PHENIX Sodium Fast Reactor irradiated CPed6106 standard fuel subassembly is suitable for obtaining experimental data on fission gas release for operating conditions similar to those foreseen for the ALLEGRO oxide core fuel pins. Alternatively, a specific irradiation program in other potentially available fast reactors (e.g. JOYO, BOR60, or in the future MBIR) could be envisaged.

In addition to the qualification of the oxide fuel, the reference GFR dense fuel (i.e. carbide fuel UPuC with composite SiC and fiber reinforced SiC clad) development efforts must continue. In particular, it is necessary to develop a ceramic clad that meets the specifications in terms of length, diameter, surface roughness, apparent ductility, level of leak tightness (including the potential need of a metallic liner on the clad), compatibility with polluted helium, and the irradiation conditions. The needs include fabrication capacities and material characterization under normal and accidental conditions for fresh and irradiated fuel.

The development and qualification of fuel for ALLEGRO reactor will require irradiation capabilities and post-irradiation examination laboratories. The first core with UOX/MOX pellets with 15-15Ti stainless steel cladding will need qualification procedures similar to that of SFRs. The refractory core with carbide pellets and SiCf/SiC cladding will have to be tested in up to high doses in high temperature reactors. Today the only material testing research reactor with fast spectrum is the BOR-60 in Russia. The planned MYRRHA and MBIR reactors could be used for irradiation purposes in the future. In order to carry out fuel examination of irradiated ALLEGRO fuel new hot cell facilities are proposed to be built in Hungary at the site of the Paks NPP.

Helium Technology

Given the high temperature environment of the ALLEGRO ceramic core, the design margins considered in terms of material characteristics, as well as in the applied thermal hydraulics correlations must be as low as possible. Therefore, air, followed by helium tests on subassembly mock-ups under representative temperature and pressure conditions are necessary to assess the heat transfer and pressure drop uncertainties for the specific GFR design.

Moreover, large-scale air and helium tests to demonstrate the passive decay heat removal function will be required for the licensing process of ALLEGRO.

UJV Rez together with its daughter company Research Center Rez (CVR) will in 2020 commission an integral experimental facility aimed at demonstrating the technical and economic feasibility of recovery of leaked helium from the guard vessel nitrogen (and helium) atmosphere.

UJV & CVR together with other academic and research partners will also experimentally assess between 2019 and 2024 the compatibility of selected heat transport systems-related structural materials with nitrogen at elevated temperatures up to 800-850°C, the coolant expected for the secondary circuit of GFRs. In addition, experimental experiences were reached in the domain of: 1) gas coolant purification including gaseous FP noble gases as Xe and Kr; and 2) helium sealing.

CVR & UJV will also analytically and experimentally assess between 2019 and 2024 the performance of disc check valves proposed by CEA for isolating the gas flow through the DHR system in reactor start-up conditions.

In support of technological developments and R&D in the fields of helium purification and tightness, tribology, high temperature materials and thermal insulation but also components development, France constructed an experimental platform the first decade of the years 2000. This helium platform was composed of several circuits or benches: HETIMO (dedicated to thermal insulation), HETIQ (dedicated to tightness of Helium seals), HPC (dedicated to purification system evaluation and chemistry control in dynamic conditions (20 g/s)), and the He Tribometer. They are responding to the needs in these technological fields. They are currently under cocoon for around 10 years. However, they could eventually cover some needs expressed by the international community after refurbishment and restart (if any dedicated funding is obtained).



Figure V-4: HETIMO.



Figure. V-5: HETIQ



Figure V-6: He Tribometer

Neutronics

In the area of neutronics, existing calculation tools and nuclear data libraries have to be validated for gas-cooled fast reactor designs. The wide range of validation studies on sodium-cooled fast reactors must be complemented by specific experiments that incorporate the unique aspects of gas-cooled designs: slightly different spectral conditions, innovative materials and various ceramic materials (UC, PuC, SiC, ZrC, Zr₃Si₂). In addition, some unique abnormal conditions (e.g. depressurization) must be considered. Unfortunately, the planned collection of data from the experimental program ENIGMA that was proposed in the past will not be possible in the zero power facility MASURCA after the decision of its final shutdown.

Components

In terms of components development and qualification, future GFR system R&D activities will focus on the following areas:

- Specific blowers and turbomachines are needed to cope with a wide range of pressure operation (from 7.0 to 0.1 MPa) with rotating parts yet retain their leak tightness.
- GFR specific solutions for the thermal barriers that are protecting the metallic structures from the hot helium during normal and transient conditions must be developed and qualified in experimental facilities.
- Valves and check-valves are critical safety components of the GFR. Qualification tests of candidate technologies for these components are needed and must be performed using a dedicated Helium loop.
- The design of passive shutdown systems will require related R&D to validate the technology based on experimental programs to be defined.
- The development of instrumentation performing under GFR conditions is one of the main challenges of this Gen-IV system. In particular, the main safety issue concerns the helium temperature measurement at the core outlet, in order to be able to detect hot spot on fuel cladding or fuel assembly plugging.
- Various fuel handling solutions will have to be qualified under representative conditions.
- Seals will have to be developed (including static helium leak tightness qualification tests).
- Optimization of design & materials selected for the DHR He/water heat exchanger including verification of its resistance to elevated temperatures in passive (natural convection) conditions.

V. GFR R&D INFRASTRUCTURES

It will very much depend on the Design Specifications for the DHR HX based on acceptance criteria & safety analyses.

- Optimization of design & materials for the core catcher.
- Optimization of design & materials for the guard vessel based on feasibility studies.
- Feasibility of the gas turbomachinery in the secondary circuit feeding primary blowers with electricity in accident conditions to maximize the period of forced convection in primary circuit.
- Optimization of design & materials selected for the main He/gas heat exchanger focused on maximization of performance & minimization of space requirements.

Materials

The main challenge for the in-core structural materials of GFR is the development of such materials, which can withstand high temperatures and fast neutron flux up to very high doses. Ceramic materials are the reference option, but composite cermet structures, refractory alloys and inter-metallic compounds can be also considered.

- The reflector material should have specific neutronic properties to reduce neutron leakage efficiently and to protect the surrounding vessels; an inter-metallic compound of Zr and Si is the candidate for this component.
- The other components (i.e. heat exchangers, tubes, blowers) of the reactor system have to be made also of refractory materials, since they will operate at high temperature. Another important requirement is the leak tightness of the components, which should be supported by special sealing materials.

The following experimental facilities could be mentioned:

- The **HTHL1** (High-Temperature Helium Loop 1) loop is built for the purpose of simulation of chemical and technical conditions of coolant of Generation-IV gas-cooled nuclear reactors (VHTR and GFR). The loop is mostly designed for long-run tests of VHTR construction materials and also for the research and development in-field of chemical technology processes for the purification of advanced gas-cooled nuclear reactor coolants. The loop was designed to allow controlled doping of impurities into the coolant including their subsequent removal.
- The **HTHL2** (High-Temperature Helium Loop 2) loop is nearly identical to HTHL1 but the test section will be inserted into the core of the LVR-15 research reactor to be exposed to neutron flux (thermal 5×10^{18} n/m²s, fast 2.5×10^{18} n/m²s).
- **Laboratory test facility for membrane separation of helium** from N₂-He mixtures is aimed at testing the recovery of helium from the GFR guard vessel atmosphere by membrane separation using commercial membrane modules originally designed for separation of nitrogen from air.
- The Karlsruhe Advanced Technologies Helium Loop (**KATHELO**) is a test facility under commissioning at Karlsruhe Institute of Technology (KIT). The loop has been designed for the testing and qualification of high temperature materials and components under severe heat loading conditions. This loop is a closed loop operated with pressurized Helium (10 MPa) at high temperature (300-800 °C).
- The Helium Loop Karlsruhe (**HELOKA-HP**) is a test facility under operation at Karlsruhe Institute of Technology (KIT). The loop has been originally designed for the testing of various components for nuclear fusion such as the Helium-Cooled Pebble Bed blanket (HCPB) and

V. GFR R&D INFRASTRUCTURES

helium-cooled-divertor for the DEMO power reactor. This loop is a closed loop operated with pressurized Helium (10 MPa) at high temperature (300-500°C).

- The **HELOKA-LP** (Helium Loop Karlsruhe-Low Pressure) loop operational ranges are defined as follows: Mass flow rate between 12 g/s and 120 g/s, inlet temperatures between 10°C and 250°C and pressure levels between 0.3–0.6 MPa.
- The Helium Loop **HEMAT** (Helium loop for Materials Testing) is designed to develop and to test new materials for efficient high-temperature applications. These are of particular interest for energy supply by renewable energy like Concentrated Solar Power (CSP), but also for fusion power and for conventional power supply. In this loop, experiments on erosion and corrosion of new materials are foreseen over a wide temperature range at moderate pressure of 3 – 6 bars.

VI. VHTR R&D INFRASTRUCTURES

The GIF VHTR system is a helium-cooled graphite moderated reactor using fully ceramic coated particle fuel. All modern designs feature passive decay heat removal, a robust coated particle fuel form, and a large graphite thermal buffer the combination of which yields an unprecedented level of inherent safety. The unique coated particle fuel and the high temperatures to which primary coolant circuit materials are exposed have meant that much of the focus of R&D has been on fuel and material qualification in support of near-term demonstration of concepts.

Key R&D challenges for the GIF VHTR System in the coming 10-15 years

- Completion of fuel testing and qualification capability (including fabrication, QA, irradiation, safety testing and PIE).
- Qualification of graphite, hardening of graphite against air/water ingress, management of graphite waste.
- Coupling technology and related components.
- Establishment of Design Codes and
- Standards for new materials and components.
- Advanced manufacturing methods (cross cutting challenge).
- Costs reduction.
- Licensing and siting.
- System integration with other energy carriers in hybrid energy systems.
- Follow-up of HTR-PM demonstration tests, engage, and enhance information
- Exchange with several start-ups, private investors, new national programs.
- HTTR safety demonstration tests and coupling to H₂ production plant.

There are various un-coordinated investigation studies taking place globally with respect to the VHTR developmental efforts. Consequently some of the required experimental facilities for research are planned, operational, in care and maintenance and/or decommissioned, some of which will require funding to continue into the future. The current effort in the VHTR concepts in RSA is centered on the lessons learned in the PBMR project with the goal to meet grid demands of the future. It is further notable that technological advances make it feasible for some of the related VHTR systems to be 3D printed.

Although the VHTR designs being pursued within the ambit of Implementing Agents might have differing goals due to the desired application(s), it would be highly encouraged to share R&D experimental facilities for the benefit of common goals and standardization. These and other focus areas that will require experimental facilities are listed here.

- Completion of fuel testing and qualification capability (including fabrication, QA, irradiation, safety testing and Post-Irradiation Examination (PIE)), to be completed in some countries. Waste reduction and fuel recycling.
- Qualification of graphite, hardening of graphite against air/water ingress, e.g. by SiC infiltration, management of graphite waste.
- Coupling technology and related components (e.g. isolation valves, intermediate heat exchangers).

VI. VHTR R&D INFRASTRUCTURES

- Establishment of Design Codes & Standards for new materials and components, including C-C and SiC-SiC composites

- Advanced manufacturing methods (cooperation with the GIF Cross-cutting Interim Task Force).

- Cost cutting R&D and interaction with EMWG and industry to optimize VHTR design.

There are efforts to develop a costing model for the proof of concept machine in South Africa, although this is a level 5 model currently, which seeks to give an indication of what it may cost to build the machine in the current economic climate.

Coupling of VHTRs with energy commercial products may offset some initial project costs, as compared to a stand-alone energy production plant. This is so because the project capital costs can be shared amongst the industries.

Other plant configurations and/or additional systems could complement the VHTR design to include flexibility of operations, such as load following, safe shutdown and so forth. Development, experimental validation, and uncertainty characterization of modern core analysis methods.

- Licensing and Siting: V&V of computer codes for design and licensing.

This requires a licensing demonstration VHTR or proof of concept plant. As part of its R&D efforts towards development of a Gen-IV VHTR, South Africa plans to build a proof of concept plant in Pelindaba. It will be used for licensing/demonstration purposes (i.e. to prove safety and operational characteristics).

Under the current regulatory regime, the improvement of nuclear regulatory license application and review processes is a requirement. This includes the establishment of a risk informed regulatory basis for VHTR reactors and sustainable fuel cycle activities. Integration with other energy carriers in Hybrid Energy Systems.

The principle of Verification and Validation (V&V) of Computer Software Codes (CSC) are the cornerstone of software accreditation before it can be applied in the analysis of nuclear reactor physics design. However, these might not be well developed in the VHTR concept, since the initiative is at its infancy in different countries.

Simplistically, verification of CSC design can be performed by means of reviews, inspections and audits – plant data, while validation provides a confirmation that the original requirements have been met through a computational modelling. The process of V&V in the VHTR requires extensive modelling of the concepts and applicable degree of accuracy. However, a more appropriate validation process needs available practical data and/or comparison of the results from another established CSC.

The update of VHTR codes will require a thorough appreciation of the varying concepts in the designs, applicability and operating regimes.

- Analysis of HTR-PM startup physics and demonstration tests
- HTTR: safety demonstration tests and coupling to H₂ production plant (subject to regulatory approval for restart).
- The demonstration of the coupling of the desalination plant onto the VHTR. The Koeberg Power Station (South Africa) is working the local nuclear regulator to explore the back fitting of a reverse osmosis plant onto existing cooling water structures. Although this concept has been

VI. VHTR R&D INFRASTRUCTURES

demonstrated in Kazakhstan, India and Japan, there are concerns about the migration of radioactive isotopes into the product water hence the proposal for a preceding “Data Collection” implementation. A similar concept could be explored with the VHTRs for heat applications including: Combined Heat and Power, desalination and so forth. This, however, would require a combined license application with the nuclear regulators.

- Enhanced information exchange among vendors, private investors, new national programs, multinational organizations, and regulators.

A specific report produced by the Euratom NC2I-R project has compiled the needs for Industrial Infrastructures including computer tools required for the licensing and demonstration of Nuclear Cogeneration technology using High Temperature Gas-cooled Reactors [1].

The methodology used consisted in confronting a bottom-up with a top-down approach. In the bottom-up phase, information was collected on existing or former infrastructures. Examples for that are known subjects from different sources such as reports from commercial companies, research centres, and the OECD TAREF database. In a parallel top-down approach, the authors have produced a priority table of critical infrastructure items and have filled in the missing information using a variety of sources including scientific literature, conference proceedings (in particular the HTR conference series), networking, information from the Generation-IV International Forum, web-browsing, expert opinion, personal communication and databases. The collected information enabled the preparation of a gap analysis to identify those R&D and Industrial Infrastructures which are not available and which would need to be built [2].

The analysis identified the gaps in industrial infrastructure and competencies for R&D that need to be bridged prior to licensing, construction and operation of an HTR demonstrator. Emphasis is given to existing industrial infrastructure and R&D competences. Based on the valuable results of the German HTR development program up to the late 1980s, significant progress has been made by several GIF signatories. The most outstanding examples are in the areas of fuel production, its quality control and qualification under irradiation, the qualification and coding of high temperature structural materials and new graphite grades (incl. through irradiation testing), component development (e.g. turbomachines, heat exchangers), helium technologies and licensing-relevant modelling (e.g. reactor physics, thermofluid dynamics, mechanics, tritium transport, source term calculations, system code integration).

<i>R&D Area</i>	<i>Gaps for Demonstrator</i>	<i>Gaps for future VHTR development</i>
Computer codes	Validation of updated codes in support of licensing Modelling of source-term (dust formation and transport)	Validation of updated codes Modelling of source-term (dust formation and transport)
Components	Component qualification in large scale facilities	Development and qualification of IHX High temperature ceramics (SiC-SiC, C-C)
Tribology and corrosion	None	Large scale facilities to measure wear and friction may be required for better estimates of dust-related source term releases
Fuel	Fuel is available, but needs qualification	Development and qualification of high temperature fuel.
Material R&D	Graphite qualification Some focused R&D on oxidation under accident conditions	Additional effort will be required for high temperature materials such as ceramics and composites, but also graphite properties at high temperature

VI. VHTR R&D INFRASTRUCTURES

Safety analysis and demonstration	Large scale loop for component testing Compliance of plant design with Safety Regulation	Effect of very high temperatures on safety margins
Multi-purpose plant	Demonstration and licensing	Demonstration of VHTR secondary function (primary function is electricity production) coupling with energy commercial products such as process heat, desalination, hydrogen production, coal gasification, metals industry and coal liquefaction. Licensing strategy for a coupled nuclear reactor site
Design and System Integration	Demonstrator design and test program	Development of a proof of concept machine built and integrated into heat intensive processes
Development of a licensing framework	Assess existing licensing framework for suitability to license HTR demonstrator for cogeneration	Establish a licensing framework in preparation of the commercial machine for VHTRs using proof of concept machine
Fuel/Graphite waste minimization and recycling	Qualify decontamination and recycling of irradiated graphite Compliance with new Nuclear Waste Directive	Evaluate direct disposal vs. reprocessing for symbiotic fuel cycles

Table VI-1: Gaps for short and long-term VHTR deployment

In addition, significant improvement was achieved in understanding the market and end-user needs so as to design a power plant accordingly. Several industrial designs worldwide reflect this development.

Due to the time gap between the last running HTR and the HTR "revival" in the 1990s, some facilities had been shut down, mothballed or refurbished to support other projects and developments. A number of them could be recovered and have already produced significant results. This situation is similar for graphite qualification.

New or repurposed test facilities have been constructed in support of China's HTR-PM demonstration, the US NGNP project, and the HTR programs in Korea and Japan, often with the support and investment of industrial partners. Universities have also constructed some smaller research facilities, particularly for materials testing and experimental thermal-fluid model validation.

In the U.K. academia and the supply chain can support modelling and simulation (using some AGR and international data); low TRL materials development making use of the High Temperature Facility (HTF) is possible. Uranium fuel R&D and PIE on irradiated materials can be performed in the UK (limited to single UK facilities). On waste management R&D, the UK has experience of managing wastes arising from HTGRs; however, there is no experience with VHTRs or the spent fuel form.

One of the components of R&D infrastructure available in Russia for the development of high temperature reactor systems is the ASTRA critical facility at NRC "Kurchatov Institute" (Moscow), where the experimental technology of modeling HTGR specific neutronic features was successfully implemented and extensive studies were carried out.

The ASTRA critical assemblies use medium-enriched uranium dioxide fuel in the form of fuel particles with multilayer coating (TRISO) distributed in the graphite matrix of spherical fuel elements, and graphite reflectors. The pebble bed with reflectors can be arranged in different configurations within a cylinder 380 cm in the outer diameter and 460 cm high.

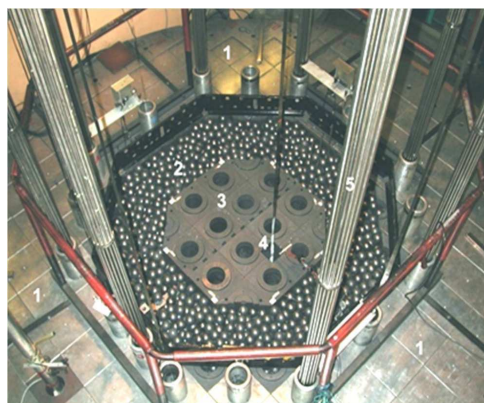

Figure VI-1: The ASTRA critical facility at NRC Kurchatov Institute in Moscow, Russia

The purpose of experiments is experimental justification of neutronic characteristics of different HTGR core configurations, as well as acquisition of experimental data for validation of calculation models and codes. List of performed experiments includes justification of conceptual decisions for the most advanced Russian HTGR designs (VG-400, VGM), including full-scale modeling (VGR-50), studies of PBMR mockup (annular core design with mixing zone from fuel and graphite elements) in support of PBMR licensing in South Africa, implementation of the Technology Development Plan in frame of the International GT-MHR Project (studies of placement of poison profiling elements in the annular core).

Future program of experiments could include measurements of HTGR core characteristics at heating of ASTRA critical assembly (temperature reactivity effect and its components, worth of control rods at various temperatures of the core and reflectors, etc).

What should not be underestimated is the time and effort required for qualification. Assuming that the currently ongoing international collaboration towards fuel and materials (metals, graphite, composites) qualification are confirmed successful, there is still work ahead in view of licensing related to computer codes and to large-scale test facilities for the qualification of components and subsystems. These include steam generators, heat exchangers, the Reactor Cavity Cooling System, circulators with magnetic bearings, isolation valves, control rod mechanisms, instrumentation and others. Specific qualification test rigs will be needed.

REFERENCES

- [1]: M.A. Fütterer, C. Auriault, O. Baudrand, G. Brinkmann, D. Hittner, S. Knol, Th. Mull, K. Stehlik, D. Vanvor, K. Verfondern, R&D and Industrial Infrastructures, Deliverable D2.21 of the EU NC2I-R project, 9 September 2015.
- [2]: S. Knol, F. Roelofs, M.A. Fütterer, P-M. Plet, D. Hittner, Report on Gap Analysis, Deliverable D2.31 of the EU NC2I-R project, 11 November 2015.

VII. SCWR R&D INFRASTRUCTURES

Key R&D challenges for the SCWR System in the coming 10-15 years

- The development of cladding materials to withstand the high pressure and high temperature environment.
- The establishment of a chemistry-control strategy to minimize water-radiolysis effect and activation-product transport.
- The optimization of the fuel assembly geometry and configuration.
- Some of these challenges can be mitigated through lowering the operating temperature of the coolant in SCWRs to reduce the peak cladding and fuel temperatures.

The Super-Critical Water-cooled Reactor (SCWR) is a high-temperature, high-pressure water-cooled reactor that operates above the thermodynamic critical point of water (i.e., 374°C, 22.1 MPa) [1]. Its main mission is to generate electricity efficiently, economically and safely. In addition, the high core outlet temperature of SCWRs (up to 625°C) facilitates co-generation, such as hydrogen production, direct heating and steam production.

Development of SCWR concepts has been based on over 50 years of design and operation experience of light-water reactors and supercritical fossil-fuel fired power plants. Existing infrastructures of these industries are applicable in support of the SCWR development. However, due to the high operating temperatures (up to 625 °C at the core outlet) and pressures (nominal 25 MPa), new facilities have been established for key technology areas among signatories of the SCWR System Arrangement [2]. Experiments performed using these facilities have enhanced the understanding of various technology areas and provided data for developing prediction methods, as well as verifying and validating analytical toolsets.

Two types of SCWR core configuration are being pursued: pressure vessel and pressure tube. These core configurations have been evolved from the light-water-cooled reactors and heavy-water cooled reactors. The balance-of-plant configuration is based on that of the fossil-fired power plant. The SCWR System Research Plan identifies key technology areas for designing SCWR (see *Figure VII-1*). Establishment of mechanical components and system configurations in the design of the core and plant facilitates meeting GIF technology goals of enhanced economics and safety. Implementation of advanced fuel and fuel cycle would enhance sustainability and proliferation resistance of SCWRs. Material candidates for in-core and out-of-core components, except for the fuel cladding, have been selected from materials established for light-water reactors and supercritical fossil-fired power plants. Identification of cladding material candidates is critical due to high pressure and high temperature operating conditions, which are well beyond the operating range of current fleet of reactors. Similarly, a chemistry strategy is needed to minimize corrosion and activity transport. An accurate prediction of cladding temperature is the key to achieving the enhanced safety technology goal since the traditional critical heat flux criteria is no longer applicable for SCWR where phase change of coolant is not present at supercritical pressures.

The development of SCWR concepts in Canada, EU and Japan are complete and have been reviewed by international peers for their viability. Other concepts being developed in China, Japan (fast spectrum) and the Russian Federation (fast spectrum) are also close to completion. Furthermore, the

VII. SCWR R&D INFRASTRUCTURES

development is being expanded to the SCW small modular reactor for deployment in small remote communities.

Experimental studies for the SCWR R&D were performed using existing facilities supporting light-water reactors and fossil-fired power plants. However, due to the high operating temperatures (up to 625 °C at the core outlet) and pressures (nominal 25 MPa) for the SCWRs, new facilities have been established for materials, chemistry, thermal-hydraulics and safety-related testing in Canada, China, Europe, Japan and the Russian Federation. Experiments performed using these facilities have enhanced the understanding of various technology areas and provided data for developing prediction methods, as well as verifying and validating analytical toolsets. This facilitates the completion of the Canadian SCWR concept in Canada, the High Performance Light Water Reactor (HPLWR) in Europe and the JSCWR in Japan [3]. The CSR-1000 SCWR concept is also close to completion in China [4].

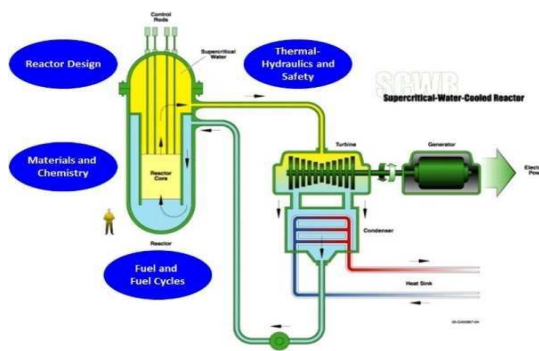

Figure VII-1: Technology Areas supporting SCWR development [1]

With the completion of the concept development, the SCWR System Research Plan identifies the path to focus on the prototype-of-a-kind SCWR development [1]. Additional infrastructures are needed to be established for achieving that goal. Experimental facilities currently available in support of the SCWR development and the identified infrastructure for developing the prototype SCWR in the next decade are described in following sections. In view of the large number of facilities available world wise, only selected facilities are introduced.

Materials and Chemistry R&D Infrastructures

Material candidates for in-core and out-of-core components, except for the fuel cladding, have been selected from materials established for light-water reactors and supercritical fossil-fired power plants. Infrastructures available in support of these reactors and plants are applicable for development and qualification of material candidates. The main issue for the identification of cladding material candidates is attributed to high-pressure and high-temperature operating conditions, which are well beyond the operating range of current fleet of reactors. Specific R&D infrastructure applicable for materials and chemistry testing at those conditions are required.

Major concerns on cladding material are creep behaviour, high temperature strength, corrosion characteristics, and stress corrosion cracking (SCC) behaviour. In addition, the adverse impact of irradiation to these behaviours and material properties is required to quantify at relevant conditions.

Canada, China and Euratom are signatories of the Materials and Chemistry Project Arrangement under the GIF SCWR System. Each signatory has established specific infrastructures to support SCWR materials and chemistry R&D. These infrastructures are summarized below. A number of SCW

facilities were also established for materials and chemistry R&D in other countries (e.g., Japan, the Russian Federation, United States of America and South Korea). These facilities are not covered here.

Canada's Infrastructure

Canada established a national program to support R&D for Gen-IV nuclear systems (referred to as the Generation-IV National Program) [5]. It was separated in two phases and was managed by Natural Resources Canada (NRCan). The first phase (Phase I) focused on basic research, including establishment of infrastructures, to support the development of the SCWR concept. Figure VII-2 shows selected facilities constructed for SCWR materials and chemistry R&D in Canada. Several static autoclaves have been constructed for corrosion testing at supercritical pressures and temperatures (the one installed at the Carleton University is illustrated). These autoclaves are applicable for studying the effectiveness of coating materials to mitigate corrosion issues.

The effect of coolant flow velocity on corrosion has been studied in flow loops with water at supercritical temperatures and pressures. These flow loops have been constructed at University of New Brunswick, NRCan Canmet-Materials Laboratories and recently at the Canadian Nuclear Laboratories.

Static autoclave systems have also been used to study material behaviours of stress-corrosion cracking (the one installed at the University of Alberta is illustrated in Figure VII-2). Test pieces included C-rings and pressurized capsules [6]. These facilities had generated key SCC data for candidate fuel cladding materials.

A suite of high-temperature mechanical testing equipment has been installed at NRCan CanmetMaterials laboratories to provide creep and other mechanical property data for candidate alloys. The creep testing systems have the capacity to measure on-line creep rate, up to 1000 °C. Special test setup also allowed measurements under compression loading. The new vacuum furnace, new rolling facility, and extrusion press have also been used in making modified stainless-steels and ferritic alloys for SCWR research.

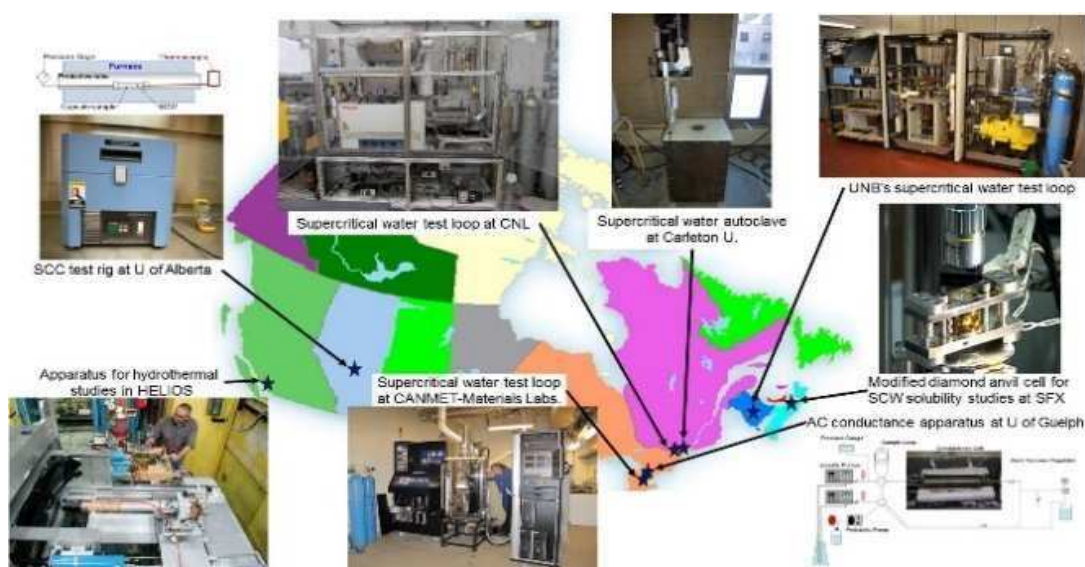

Figure VII-2: Infrastructures for SCWR Materials and Chemistry R&D in Canada

Two main issues in water chemistry are corrosion product transport and radiolysis. Diamondanvil cells coupled with X-ray absorption fine structure spectroscopy were constructed at the St. Francis Xavier University to characterize solubility of metal oxides in supercritical water [7]. A state-of-the-art high-pressure flow alternating current conductance apparatus was established at the University of Guelph to determine the association constants of model fission products at temperatures up to 350 °C [8]. A unique bench-scale flow loop was built at the Trent University to study the effects of pH control additives and the slow release of metallic ions in SCW as well as corrosion of alloys in SCW [9].

The synchrotron operated by TRIUMF at Canada's National Laboratory for Particle and Nuclear Physics has been used to understand the behaviours of water radiolysis in SCW. An advanced proton accelerator at Queen's University was used to introduce irradiation damage (by protons) into materials for studying materials behaviour under neutron bombardment.

China's Infrastructure

Material and chemistry R&D for SCWR are being performed at Nuclear Power Institute of China (NPIC), Shanghai Jiao Tong University (SJTU) and the University of Science and Technology in Beijing (USTB) in China. Figure VII-3 shows infrastructures for material and chemistry R&D at these organizations.

A general corrosion test facility was developed jointly by China and Japan and has been installed at NPIC for material testing. It consists of an autoclave and a flow loop designed for high pressure and high temperature operations. A separate test facility for stress corrosion cracking behaviours of materials has also been constructed at NPIC. These facilities support the establishment of cladding material candidates for the Chinese SCWR concept (CSR-1000).

A SCW stress corrosion cracking testing facility has also been installed at SJTU in support of the cladding-material selection [10]. Different types of material were examined. A slow strain rate testing facility was constructed to study the growth behaviours of cracks in materials.

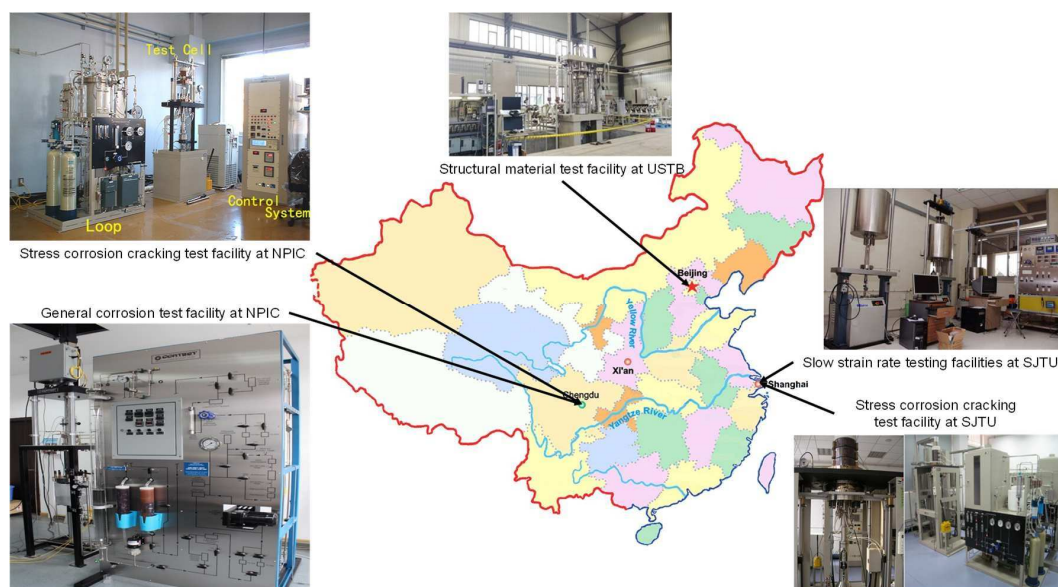

Figure VII-3: Infrastructures for SCWR Materials and Chemistry R&D in China

EU's Infrastructure

Figure VII-4 shows infrastructures for material and chemistry R&D at various countries within the European Union. Several SCW autoclaves for corrosion and stress corrosion cracking tests have been constructed for material testing at Centrum výzkumu Řež (CVR) in Czech Republic, Joint Research Centre (JRC) in the Netherlands [11], Centro de Investigaciones Energéticas, Medioambientales y Tecnológicas (CIEMAT) in Spain and Valtion Teknillinen Tutkimuskeskus (VTT) in Finland [12]. VTT developed also a miniature SCW autoclave with bellows-based loading device for stress-corrosion cracking tests [13]. JRC-Petten developed a new measurement facility using the electrochemical impedance spectra (EIS) technique to study radiolysis in supercritical water.

An in-reactor SCW loop has recently been constructed and installed into the LVR-15 reactor of CVR in Czech Republic for material corrosion testing. This facilitates the study of the irradiation effect on material characteristics. The test section is installed at one of the sites in the reactor, but most components of the facility are located out-of-core. The photo in the figure illustrates the out-of-core components.

Thermal-Hydraulics and Safety R&D Infrastructures

Experimental data on heat transfer in supercritical flow are required for the development and optimization of the fuel assembly concept. Performing heat-transfer experiments with SCW flow is complex and expensive due primarily to the harsh operating environment. Surrogate fluids (such as carbon dioxide and refrigerants) have been used for modelling water in heat transfer studies. This approach is valid for improving the understanding of heat-transfer phenomena and examining separate effects.

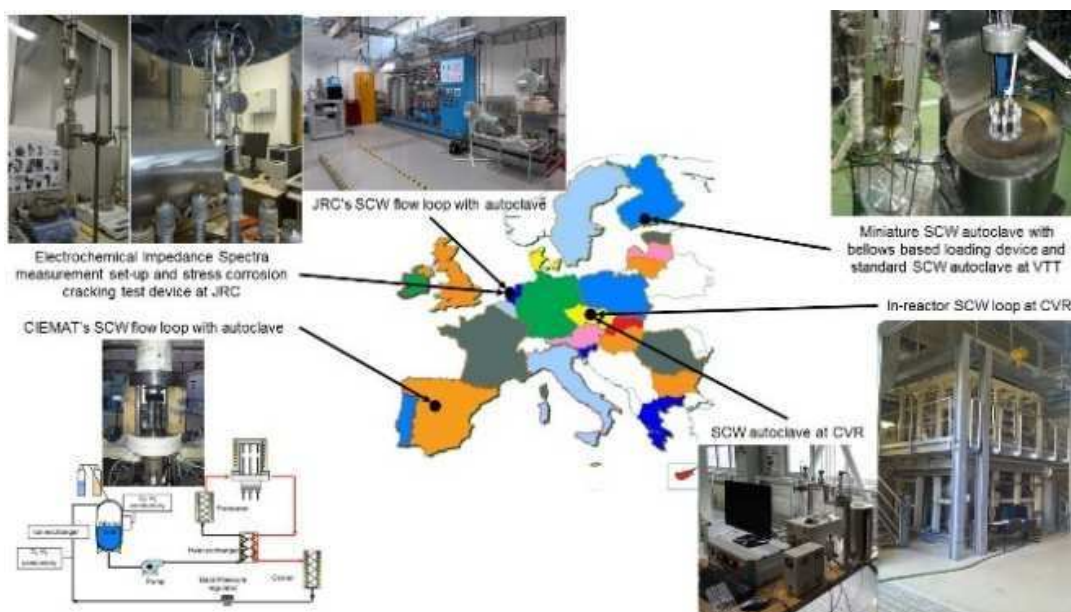

Figure VII-4: Infrastructures for SCWR Materials and Chemistry R&D in EU

Infrastructures established by signatories of the Thermal-Hydraulics and Safety Project Arrangement in the GIF SCWR System (i.e., Canada, China and EU) are described below. Other facilities applicable for thermal-hydraulics and safety experiments at supercritical pressures are available in Japan, the Russian Federation, United States of America, South Korea and India.

Canada's Infrastructure

Several facilities for thermal-hydraulics and safety-related tests at supercritical pressures have been established in Canada to support the Phase-I Generation-IV National Program [5]. Figure VII-5 shows the facilities with water, carbon dioxide or refrigerant as working fluids.

A supercritical water loop has recently been constructed at the Carleton University. It is applicable for thermal-hydraulics tests with tubes, annuli and small bundle assemblies. A complementary test facility was also constructed for experiments with Refrigerant-134a as coolant through a tube, an annular channel, and a 7-element bundle at supercritical pressures [14]. It has been used to study experimentally the effect of spacer configuration and size on supercritical heat transfer in support of the development of fuel assembly concept for the SCWR.

A test loop was constructed at the University of Ottawa to investigate heat transfer in tubes and a 3-rod bundle with carbon-dioxide flow [15]. Its design pressure is up to 11 MPa, which can accommodate other fluids (such as refrigerants) at supercritical pressures and even water at sub-critical pressures. Experimental data from these tests have been used in assessment of prediction methods for heat transfer, sub-channel codes (such as ASSERT), and computational fluid dynamics tools (such as STAR CCM+).

A natural-circulation test facility with carbon dioxide as the working fluid was established at the University of Manitoba [16]. It facilitates testing with single and parallel tubes in vertical or horizontal orientation. Experimental data from these tests have been applied in establishing the stability boundaries over a range of flow conditions and assessing the analytical model and system codes (such as CATHENA).



Figure VII-5: Infrastructures for SCWR Thermal-Hydraulics and Safety R&D in Canada

A water test facility was constructed at École Polytechnique de Montréal to study critical-flow behaviors [17]. It consists of a nozzle section with a small opening. Water at supercritical pressures is

discharged through the nozzle to a medium pressure test facility (which facilitates the control of discharged pressures other than atmospheric). Experimental results obtained with 2 sharp-edge nozzles of different sizes of opening have been used to assess the critical-flow models implemented in the system codes, which are being applied in the postulated large-break loss-of-coolant accident.

China's Infrastructure

Figure VII-6 shows thermal-hydraulics facilities available in China. Several test loops were constructed at the Nuclear Power Institute of China to support the development of the CSR-1000. A small-scale SCW test loop was designed for thermal-hydraulics testing using tubes and annuli. Testing with bundle subassemblies has been performed with the large-scale SCW test loop, which provides higher power and flow than the small-scale test loop. Experimental data have been applied in developing heat-transfer correlations for the CSR-1000 fuel assembly and validating analytical tools (such as SC-TRAN). In addition, a natural-circulation test loop was constructed to investigate heat transfer and stability [18], [19]. It was designed for experiments with water flow but has also been adopted for experiments using carbon dioxide as working medium. Experimental data are available to define the stability boundaries of supercritical flow and fluid-to-fluid modelling criteria.

A SCW heat-transfer test loop has also been constructed for testing with tubes, annuli and 4-rod bundles at the Shanghai Jiao Tong University [20], [21]. The 4-rod bundle design simulated the proposed fuel for the GIF collaboration on fuel qualification testing at CVR. Two different types of spacing devices (i.e., grids and wrapped wires) were tested to examine their impact on heat transfer. Transient experiments were also performed to quantify the impact of power, flow and pressure variations on heat transfer.

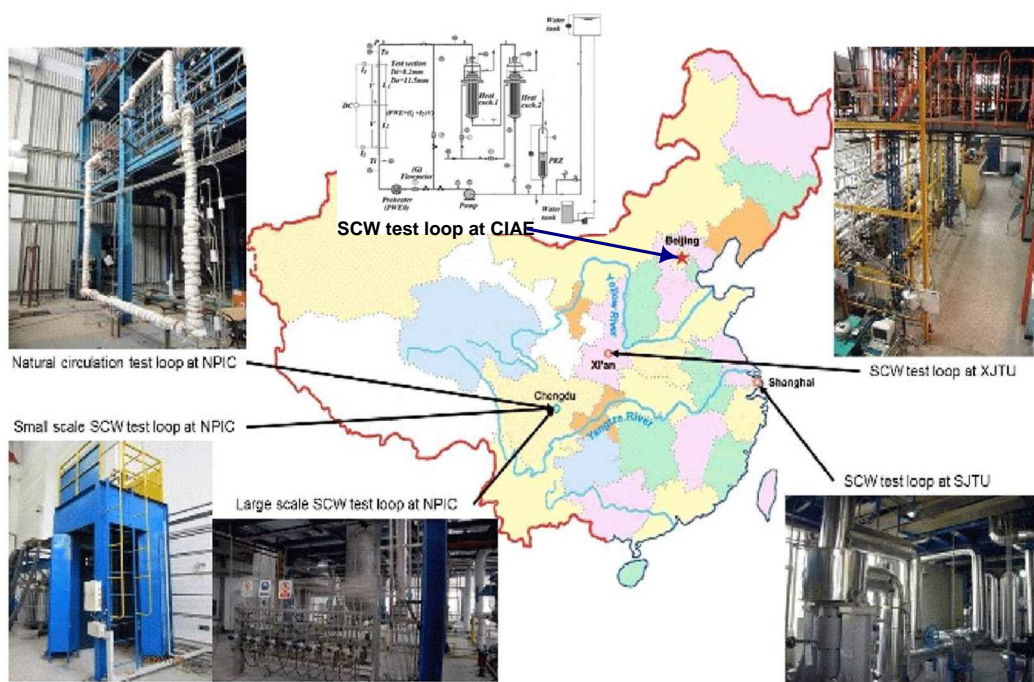

Figure VII-6: Infrastructures for SCWR Thermal-Hydraulics and Safety R&D in China

The SCW heat-transfer test loop at Xi'an Jiaotong University was constructed mainly for supporting the SC fossil-fired power plant. It has been applied for heat-transfer experiments with tubes,

annuli and a 4-rod bundle (which also simulated the fuel design for the Czech Republic fuel qualification testing) in support of SCWR development [22], [23]. Effects of flow area and spacer on heat transfer were examined in the annuli tests. Detailed temperature distributions along heated surfaces of the 4-rod bundle were obtained to quantify variations in sub-channels and gaps.

The test loop at the China Institute of Atomic Energy (CIAE) is applicable for natural or forced circulation experiments with water as coolant. It consists of a pump, two heat exchangers, test section, a preheater and a power supply 160 kW. Fluid temperatures at various locations are measured with Ktype sheathed thermocouples. Turbine flowmeters are installed to measure the flow rate. An absolute pressure transducer is used to measure the outlet pressure and a differential pressure transducer to measure the pressure loss over the test section. The maximum design pressure of the loop is 25.9 MPa, the maximum mass flow rate is 0.39 kg/s and the maximum loop temperature is 600 °C.

EU's Infrastructure

Supercritical heat transfer facilities were constructed at the Karlsruhe Institute of Technology (KIT) in Germany and the Hungarian Academy of Sciences (HAS) in Hungary within the EU. Figure VII-7 shows EU's facilities in support of SCWR development.

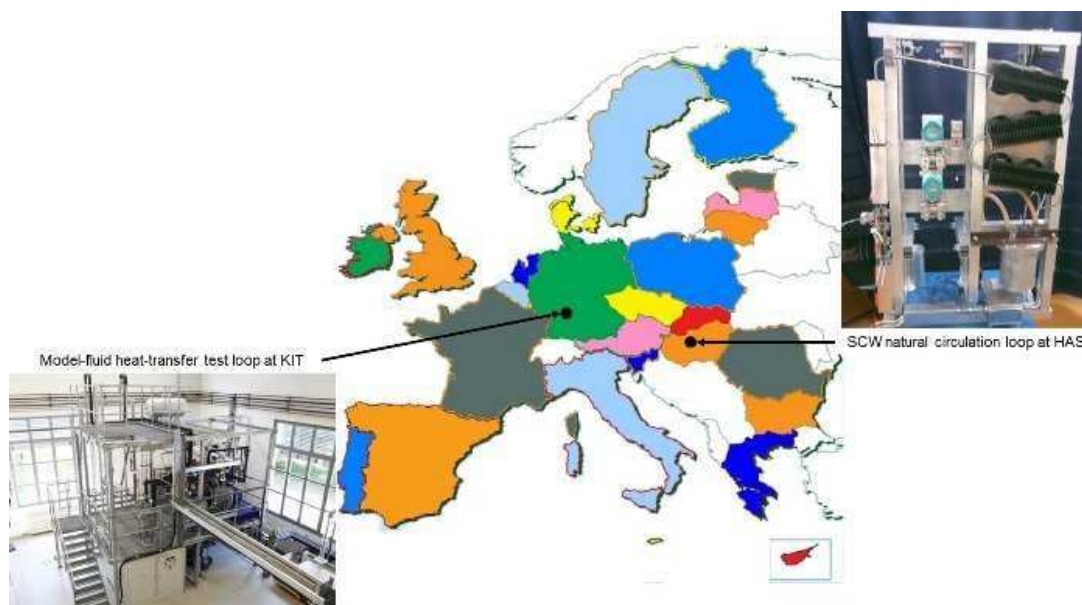

Figure VII-7: Infrastructures for SCWR Thermal-Hydraulics R&D in EU

The model-fluid test loop at KIT was designed to use refrigerants as the working fluid. Experiments with Refrigerant-134a in tubes were performed to provide data for validating heat-transfer correlations and fluid-to-fluid modelling parameters.

A test loop has been installed at HAS to study natural circulation behaviors with water at supercritical pressures [24]. It was also used to examine the flow structure of supercritical water using the neutron radiography technique [25].

Other Infrastructure

Infrastructures capable of operating at supercritical pressures in support of thermal hydraulics R&D have also been established at institutes of non-GIF partners. These infrastructures are documented in the IAEA technical document, which summarized the contributions from participants of the Cooperative Research Project on SCWR thermal-hydraulics [26].

Natural Circulation Loop at Bhabha Atomic Research Centre

The test loop of Bhabha Atomic Research Centre (BARC) is referred to as the Supercritical Pressure Natural Circulation Loop (SPNCL) [27]. A schematic diagram of the experimental loop is illustrated in *Figure VII-8*. The test loop was constructed for natural convection experiments using carbon dioxide or water a coolant. It is made of stainless steel (SS-347) with an inside diameter (ID) of 13.88 mm and an outside diameter (OD) of 21.34 mm. Two heater test sections and two cooler test sections are installed in the loop for four different testing orientations: Horizontal Heater Horizontal Cooler (HHHC), Horizontal Heater Vertical Cooler (HHVC), Vertical Heater Horizontal Cooler (VHHC) and Vertical Heater Vertical Cooler (VHVC).

The annulus in the cooler has an inside diameter of 77.9 mm and an outside diameter of 88.9 mm. It is cooled with water as the secondary coolant. A pressurizer has been installed to adjust the pressure of the loop. The loop is equipped with two rupture disks to avoid over pressure incidents. Forty-four K-type thermocouples are installed along the loop to measure temperatures of the primary fluid, secondary fluid and outer wall of the heater. Loop pressures are measured using two pressure transducers at the pressurizer and the heater outlet. A wattmeter is used to measure the applied voltage for determining the heating power (at the maximum of 10.5 kW). The secondary flow rate is measured using three parallel flowmeters.

The maximum design pressure of the loop is 30 MPa, the maximum mass flow rate is 0.13 kg/s and the maximum loop temperature is 600 °C.

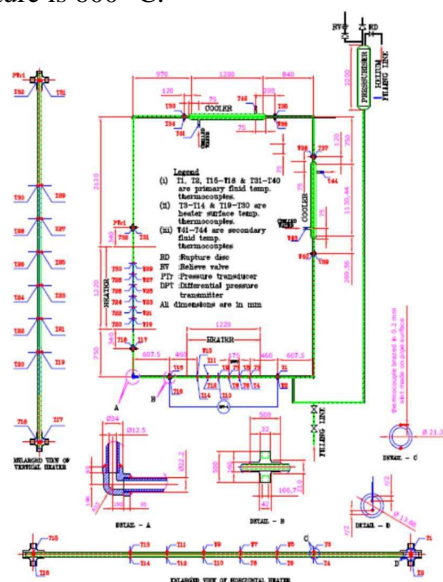

Figure VII-8: Schematic diagram of Supercritical Pressure Natural Circulation Loop (BARC) [27]

Experimental Loop at National Technical University of Ukraine

The test loop at the National Technical University of Ukraine (NTUU) is schematically shown in [Figure VII-9](#) [28]. It consists of a closed loop of stainless-steel piping with a forced circulation of water at the maximum design pressure of 28 MPa and temperature of 600 °C. The loop contains a boosting pump and two plunger pumps that can increase the pressure up to 70 MPa. Other components include a set of pressure regulating valves, a tube-in-tube preheater and a 75-kW electrical preheater. A turbine type flowmeter is used to measure the mass-flow rate (at the maximum of 0.19 kg/s). The power supply is capable to deliver a maximum of 120 kW.

Experimental Loop at University of Wisconsin-Madison

The University of Wisconsin–Madison high-pressure heat transfer test facility consists of a primary testing flow loop and a secondary flow loop used for heat removal. A picture of both flow loops is shown in [Figure VII-10](#) (the flow path in the primary loop is illustrated with the red arrows while that in the secondary loop with the blue arrows). Both loops interface at the main heat exchanger. Water is circulated through the test section or through an unheated recirculation branch fitted with an orifice plate. Water from both branches merges after the test section. A portion of the merged water is cooled inside the heat exchanger while the other recirculated back to the pump. The amount of water through the heat exchanger is controlled with a bypass valve. Water from the heat exchanger recombines with the bypass flow and re-enters the pump. An accumulator tank is installed to accommodate thermal expansion of the fluid. A cylinder of argon gas is connected to the loop for establishing the system pressure.

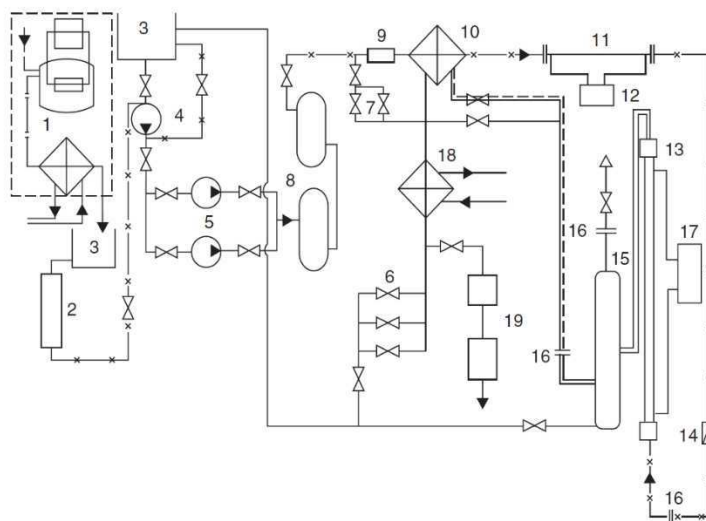

Figure VII-9: Schematic diagram of the Supercritical Pressure Test Loop at NTUU [28]



Figure VII-10: Photo showing the primary and secondary flow loops at University of Wisconsin-Madison

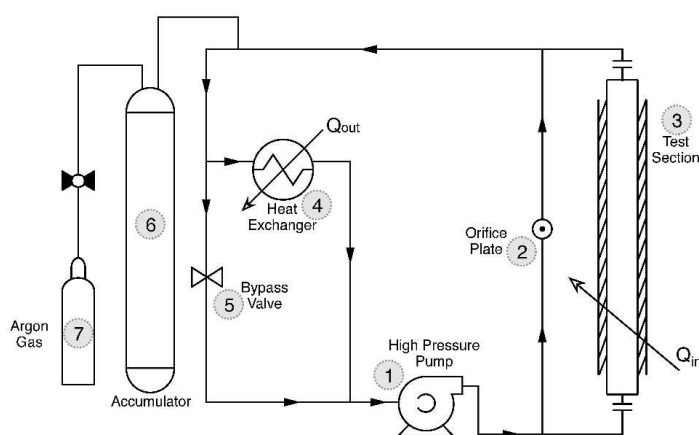

Figure VII-11: Schematic diagram of the flow loops at University of Wisconsin-Madison

Future Infrastructure Needs

The GIF SCWR System Research Plan identifies several key components in each project before proceeding to the deployment phase. Required infrastructures are described below for selected components only. A detailed review is ongoing for establishing future needs to support design and deployment of SCWRs.

System Integration and Assessment

A prototype fueled loop and a prototype-of-a-kind demonstration SCWR are required for the System Integration and Assessment Project. The fuel loop is needed to qualify the SCWR fuel and demonstrate the capability to design and operation of an in-reactor supercritical-pressure fuel facility (which is a pre-requisite for the demonstration plant). While the supercritical water material test loop recently constructed at CVR in Czech Republic has provided ample experience on design, construction, installation, licensing and operation, further complexity is anticipated for the design and construction of an in-reactor fuel loop. Figure VII-112 illustrates the SCW loop and test section installed at CVR in Czech Republic. A similar test section can be designed for fuel test in the same loop to obtain operating experience and much needed fuel information.

Another potential site for SCWR fuel irradiation is the proposed facilities to be constructed at the new research reactor of NPIC in China (see Figure VII-123). A design of the fuel assembly for testing has to be proposed. International collaborations are required for achieving the test.



Figure VII-12: In-Reactor SCW Loop and Test Section at CVR in Czech Republic

Reactor physics analyses have been performed using analytical tools developed for light-water and heavy-water reactors. Nuclear data are available for high-temperature conditions but not at relevant pressures. Previous analyses considered the effect of pressure on reactor physics parameters is small. However, nuclear data would be required for the construction of the demonstration SCWR plant.

A test facility has been proposed to obtain reactor physics data in the Zero Energy Deuterium (ZED-II) research reactor at Canadian Nuclear Laboratories (see Figure VII-134). It consists of a channel housing the fuel assembly, which will be inserted into the reactor. Two phases at high temperatures are being considered: low-pressure tests and high-pressure tests. A feasibility study for the design and installation is being carried out.

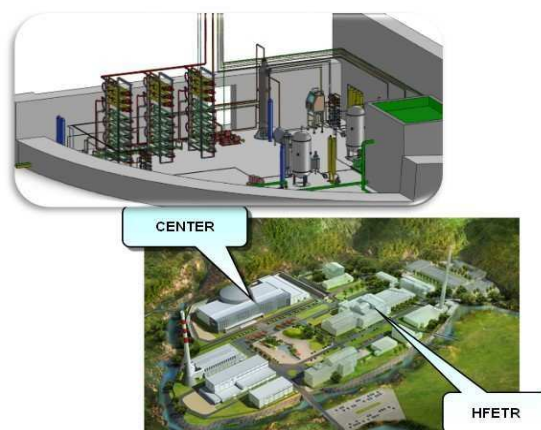

Figure VII-13: Proposed fuel irradiation facilities at NPIC in China



Figure VII-14: ZED-II Reactor for Physics Experiments in Canada

A separate test facility is needed to understand the structure of the water at supercritical pressures. It has been designed to observe the change in fluid structure using the neutron scattering technique. Construction will be initiated once a collaboration is established with the neutron beam facility.

A demonstration SCWR plant is required before deployment. NPIC has proposed to design and construct a prototype SCWR, which simulates their CSR-1000 design. The power rating would be 150 MWe matching the requirement for the super-critical pressure turbine. This small size prototype is representative to Euratom's High Performance Light Water Reactor, Japan's SCWR and a fuel channel of Canada's pressure-tube type SCWR. Therefore, a strong collaborative effort can be established in its design and construction.

Materials and Chemistry

Future development on materials and chemistry remains focusing on the cladding, which would operate at high pressure and high temperature conditions. A significant number of corrosion and stress corrosion-cracking testing have been performed for cladding material candidates in out-reactor facilities. An irradiation facility is required to examine the effect on material properties and characteristics.

Autoclaves currently used in corrosion and stress-corrosion-cracking tests are limited to supercritical water temperatures at about 650 C, which is lower than anticipated cladding temperatures of 700-800 C during normal operations and 1200 C during postulated accidents. High-temperature autoclaves are required to extend testing to relevant conditions of interest.

Mechanical properties for cladding materials are generally available at temperatures up to about 800°C. High-temperature test facilities are required to obtain mechanical properties at relevant conditions of interest.

Thermal-Hydraulics and Safety

The SCWR System Research Plan identifies the “Integral Facility Tests” as the major component for licensing of the demonstration SCWR plant and deployment. Performing these tests would require an integral test facility to demonstrate the effectiveness of the safety system design. While several SCWR core concepts have been proposed, their safety systems have been evolved mainly from the advanced boiling water reactor (in particular the thermal-spectrum SCWRs) and their operating conditions are similar. This could lead to joint design and construction of the facility.

Design and construction of a full-scale integral facility are time consuming and costly. A scaled system could be applicable to examine the phenomena and minimize the time and cost. Scaling analyses

have been performed for major components in the safety system to confirm feasibility. An integral analysis is being carried out to quantify the appropriate scaling factor using a safety analytical tool.

Thermal-hydraulics experiments were performed using simple channels (such as tubes and annuli) and bundle subassemblies with three, four or seven rods. Licensing of the demonstration unit and full-scale SCWR plant would require thermal-hydraulics data for full-scale fuel assemblies. Power supplies and pumps installed at test facilities described in Section III are insufficient for performing full-scale bundle tests. Significant expansion of current facilities is required for licensing purposes.

In conclusion, a large number of experimental facilities are available to support the development of SCWRs. Fundamental R&D studies have been performed to provide experimental data for improving the understanding of the technologies, developing prediction methods and validating models/codes. Irradiation facilities are available, but design and installation of in-reactor supercritical water loops are challenging. Large-scale facilities capable of operating at relevant pressures and temperatures are required. Completing the installation of these infrastructures would expedite the demonstration and deployment of SCWR plants.

Nomenclature

BME	Budapest University of Technology and Economics
CIEMAT	Centro de Investigaciones Energéticas, Medioambientales y Tecnológicas
CVR	Centrum výzkumu Řež
EIS	Electrochemical Impedance Spectra
EU	European Union
Gen-IV	Generation-IV
GIF	Generation-IV International Forum
HAS	Hungarian Academy of Sciences
HPLWR	High Performance Light Water Reactor
JRC	Joint Research Centre
JSCWR	Japan SCWR
KIT	Karlsruhe Institute of Technology
NPIC	Nuclear Power Institute of China
NRCan	Natural Resources Canada
R&D	Research and Development
SC	Super-Critical
SCC	Stress Corrosion Cracking
SCW	Super-Critical Water
SCWR	Super-Critical Water-cooled Reactor
SJTU	Shanghai Jiao Tong University
USTB	University of Science and Technology in Beijing
VTT	Valtion Teknillinen Tutkimuskeskus (Technical Research Centre of Finland)
XJTU	Xi'an Jiaotong University
ZED	Zero Energy Deuterium

REFERENCES

- [1]: OECD Nuclear Energy Agency, "Technology Roadmap Update for Generation-IV Nuclear Energy Systems", Jan. 2014.
- [2]: L.K.H. Leung, Y.-P. Huang, R. Novotny, S. Penttilä, A. Sáez-Maderuelo and M. Krykova, "R&D Experimental Capabilities for Advancing GIF SCWR System in the Next Decade", Proc. 2018 GIF Symposium, Paris, France, Oct. 16-17, 2018.
- [3]: Schulenberg, T. and Leung, L. "Super-critical water-cooled reactors", Handbook of Generation-IV Nuclear Reactors, Editor: I.L. Pioro, Woodhead Publishing Series in Energy: 103, 2016.

- [4]: IAEA, "Status Report - Chinese Supercritical Water-Cooled Reactor (CSR1000)", IAEA Advanced Reactors Information System (ARIS) Database, December, 2015.
- [5]: Pynn, G. et al. (2016), "Canada's Generation-IV National Program", *CNL Nuclear Review*, Vol. 5, No. 2, pp. 173-179.
- [6]: Swift, R., Cook, W., Bradley, C. and Newman, R.C., "Validation of Constant Load C-Ring Apex Stresses for SCC Testing in Supercritical Water," *Journal of Nuclear Engineering and Radiation Science*, Vol. 3, No. 2, pp. 021004-021004-7, 2017.
- [7]: Mayanovic, R.A. et al., G., "Monitoring Synchrotron X-ray-Induced Radiolysis Effects on Metal (Fe, W) Ions in High-Temperature Aqueous Fluids", *Journal Synchrotron Radiation*, Vol. 19, pp. 797-805, 2012.
- [8]: Zimmerman, G.H., Arcis, H. and Tremaine, P., "Ion-pair formation in strontium chloride and strontium hydroxide solutions under supercritical water reactor operating conditions," *Proceeding of the 5th International Symposium on Supercritical Water-Cooled Reactors (ISSCWR-5)*, Vancouver, BC, Canada, 13-16 March 2011.
- [9]: Carvajal-Ortiz, R.A., Plugatyr, A. and Svishchev, I.M., "On the pH Control at Supercritical Water-Cooled Reactor Operating Conditions", *Nuclear Engineering and Design*, Vol. 248, pp. 340-342, 2012.
- [10]: Guo, X.-L. et al., "A research on the corrosion and stress corrosion cracking susceptibility of 316L stainless steel exposed to supercritical water", *Journal of Corrosion Science*, Vol. 127, pp. 157-167, 2017.
- [11]: Novotny, R., Janík, P., Penttilä, S., Hähnera, P., Macák, J., Siegl, J. and Haušil, P., "High Cr ODS steels performance under supercritical water environment", *Journal of Supercritical Fluids*, Vol. 81, pp. 147-156, 2013.
- [12]: Penttilä, S., Toivonen, A., Li, J., Zheng, W. and Novotny, R., "Effect of surface modification on the corrosion resistance of austenitic stainless steel 316L in supercritical water conditions", *Journal of Supercritical Fluids*, Vol. 81, pp. 157-163, 2013.
- [13]: Penttilä, S. et al., A., "Miniature autoclave and double bellows loading device for material testing in future reactor concept conditions - Case supercritical water", *Jour. of Nuc. Eng. and Rad. Science*, Vol. 4, No. 1, pp. 011016-7, 2017.
- [14]: Balouch, M. and Yaras, M.I., "Design of an R-134a Loop for Subcritical and Supercritical Forced-Convection Heat Transfer Studies", *Proc. of the Int. Conf. on Future of Heavy Water Reactors*, Ottawa, ON, Canada, 02-05 October 2011.
- [15]: Jeddi, L., Jiang, K., Tavoularis, S. and Groeneveld, D.C., "Preliminary Tests at the University of Ottawa Supercritical CO₂ Heat Transfer Facility," *Proceeding of the 5th International Symposium on Supercritical Water-Cooled Reactors (ISSCWR-5)*, Vancouver, BC, Canada, 13-16 March 2011.
- [16]: Mahmoudi, J. et al., "Experimental Thermal-Hydraulic Analysis of Supercritical CO₂ Natural Circulation Loop", *Proc. of the 33rd CNS Annual Conf./36th Annual CNS/CNA Student Conference*, Saskatoon, SK, Canada, 10-13 June 2012.
- [17]: Muftuoglu, A. and Teysseidou, A., "Experimental Study of Abrupt Discharge of Water at Supercritical Conditions", *Experimental Thermal Fluid Science*, Vol. 55, pp. 12-20, 2014.
- [18]: Xiong, T., Yan, X., Xiao, Z.-J., Li, Y.-L., Huang, Y.-P. and Yu, J.-C., "Experimental study on flow instability in parallel channels with supercritical water", *Annals of Nuclear Energy*, Vol. 48, pp. 60-67, 2012.
- [19]: Liu, G.-X., Huang, Y.-P., Wang, J.-F., Lv, F. and Leung, L.K.H., "Experiments on the basic behavior of supercritical CO₂ natural circulation", *Nuclear Engineering and Design* Vol. 300, pp. 376-383, 2016.
- [20]: Hu, Z.-X. and Gu, H.-Y., "Heat transfer of supercritical water in annuli with spacers", *Int. Jour. of Heat and Mass Transfer*, Vol. 120, pp. 411-421, May 2018.
- [21]: Gu, H.Y., Hu, Z.X., Liu, D., Xiao, Y. and Cheng, X., "Experimental studies on heat transfer to supercritical water in 2 × 2 rod bundle with two channels", *Nuclear Engineering and Design*, Vol. 291, pp. 212-223, 2015.
- [22]: Wu, G. et al., "Experimental Investigation of Heat Transfer for Supercritical Pressure Water Flowing in Vertical Annular Channels", *Nuclear Engineering Design*, Vol. 241, Issue 9, pp. 4045-4054, 2011.
- [23]: Wang, H., Bi, Q., and Leung, L.K.H., "Heat Transfer from a 2×2 Wire-Wrapped Rod Bundle to Supercritical Pressure Water", *Int. J. of Heat and Mass Transfer*, Vol. 97, pp. 486-501, 2016.
- [24]: Kiss, A., Balaskó, M., Horváth, L., Kis, Z. and Aszódi, A., "Experimental investigation of the thermal hydraulics of supercritical water under natural circulation in a closed loop", *Annals of Nuclear Energy*, Vol. 100, pp. 178-203, 2017.
- [25]: Balaskó, M. et al., "Study on the properties of supercritical water flowing in a closed loop using dynamic neutron radiography", *Physics Procedia*, Vol. 43, pp. 254 - 263, 2013.
- [26]: IAEA, "Understanding and Prediction of Thermal-Hydraulics Phenomena Relevant to Supercritical Water-Cooled Reactors", *TECDOC in preparation*.
- [27]: Vijayan, P.K., Sharma, M., Pilkhwal, D.S., "Steady state and stability characteristics of a supercritical pressure natural circulation loop (SPNCL) with CO₂", *BARC Report--2013/E/003*, 2013.
- [28]: Pis'mennyy, E.N. et al., "Experimental study on temperature regimes to supercritical water flowing in vertical tubes at low mass fluxes", *Proc. 7th International Conference GLOBAL-2005*, Tsukuba, Japan, Oct. 9-13, 2005.

VIII. MSR R&D INFRASTRUCTURES

Key R&D challenges for the MSR System in the coming 10-15 years

- Development of salt and material combinations (characterization and qualification).
- Development of integrated (physics and fuel chemistry) reactor performance modelling and safety assessment capabilities.
- Demonstration of the MSR safety characteristics at laboratory level and beyond.
- Establishment of a MSR infrastructure and economy that includes affordable and practical systems for the production, processing, transportation, and storage of radioactive salt constituents.
- Development of the MSR licensing and safeguards framework development.
- Progress towards MSR demonstration (IMSR TE, MCFR Terrapower, MOSART, TMSR-LF1).

From the 1940s up to now, many liquid fueled MSR concepts have been proposed all over the world using different salt compositions (chlorides or fluorides...) basing on governmental or private support. Proposed neutron spectra range from very thermal to very fast and include time varying spectra. Almost every known form of fissile / fertile material or fuel cycle is under consideration as a fuel source. Most of the designs remain at the concept study or lab scale development phase. Even for the concepts driven by private companies, proprietary restrictions on design information limits the accuracy of any evaluation using only public data.

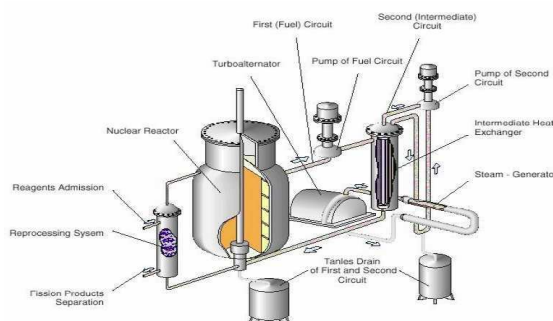

Figure VIII-1: Liquid Fuel MSR system with Processing Unit

The 8 MWt Molten-Salt Reactor Experiment (MSRE) test reactor at US ORNL went critical in 1965 and operated with great success in a thermal neutron spectrum for 4.5 years until its shutdown in Dec. 1969. The fuel salt for the MSRE was $\text{LiF-BeF}_2\text{-ZrF}_4\text{-UF}_4$ (65-29-5-1 mol. %), moderated by reactor dense graphite, its secondary coolant was molten 2LiF-BeF_2 salt mixture. The MSRE operated with three different fissile fuels: ^{233}U , ^{235}U , and ^{239}Pu . All metallic parts of the system in contact with the salt were made from the nickel-based Hastelloy-N alloy.

Main mission of the MSR pSSC is to support development of new concepts that have the potential to provide significant safety and economic improvements over existing reactors [1]. Within the MSR pSSC, R&D is performed under an MOU signed by Euratom, France, Russia, Switzerland, the United States and Australia, with Canada, China, South Korea and Japan as observers.

VIII. MSR R&D INFRASTRUCTURES

List of the selected liquid fuel systems, under consideration of the MSR pSSC, is given below:

Name	Developer	Power, MWt	Fuel / Carrier / Moderator
Thermal Spectrum Liquid Fuel MSRs			
Thorium Molten Salt Reactor, Liquid Fuel (TMSR-LF)	SINAP, China	395	ThF ₄ - ²³³ UF ₄ / ⁷ LiF-BeF ₂ / Graphite
Integral Molten Salt Reactor (IMSR)	Terrestrial Energy, Canada and USA	400	UF ₄ / Fluorides / Graphite
ThorCon Reactor	ThorCon International, Singapore	557*2	UF ₄ / NaF-BeF ₂ / Graphite
Liquid-Fluoride Thorium Reactor (LFTR)	Flibe Energy, USA	600	ThF ₄ - ²³³ UF ₄ / ⁷ LiF-BeF ₂ / Graphite
Advanced Molten-salt Break-even Inherently-safe Dual-mission Experimental and Test Reactor (AMBIDEXTER)	Ajou University, Republic of Korea	250	²³³ UF ₄ -ThF ₄ / ⁷ LiF-BeF ₂
Process Heat Reactor	Thorenco, USA	50	UF ₄ / NaF-BeF ₂ , / Be rods
Stable Salt Thermal Reactor (SSR-U)	Moltex Energy, UK	300-2500	UF ₄ / Fluorides / Graphite
Fast/Epithermal Spectrum Liquid Fuel MSRs			
Molten Salt Fast Reactor (MSFR)	SAMOFAR, France – EU - Switzerland	3000	ThF ₄ -UF ₄ / ⁷ LiF-
Molten Salt Actinide Recycler and Transformer (MOSART)	Kurchatov Institute, Russia	2400	TRUF ₃ or ThF ₄ -UF ₄ / ⁷ LiF-BeF ₂
U-Pu Fast Molten Salt Reactor (U-Pu FMSR)	VNIINM, Russia	3200	UF ₄ -PuF ₃ / ⁷ LiF-NaF-KF
Stable Salt Fast Reactor (SSR-W)	Moltex Energy, UK	750-2500	PuF ₃ / Fluorides
TerraPower MSFR (MCFR)	TerraPower (USA)	30	U- Pu / Chlorides
Molten Chloride Salt Fast Reactor (MCFR)	Elysium Industries (USA and Canada)	100-5000	U-Pu / Chlorides

Table VIII-1: The selected liquid fuel systems

Canada, China, Japan, and South Korea are focused on the development of the small and medium power liquid fuel units with thermal spectrum graphite moderated cores. In China, the Thorium Molten Salt Reactor (TMSR) Program was initiated by the Chinese Academy of Sciences (CAS) in 2011, which involves a closed U-Th fuel cycle for MSR.

Fast MSRs have large negative reactivity coefficients, a unique safety characteristic not found in solid-fuel fast reactors. Compared with solid-fuelled reactors, these systems have lower fissile inventories, no radiation damage constraints on attainable fuel burnup, no used nuclear fuel, no requirement to fabricate and handle solid fuel, and a homogeneous isotopic composition of fuel in the reactor. Developments in Russia on the 1.0 GWe molten-salt actinide recycler and transmuted (MOSART) [2] and in France, Euratom and Switzerland on the 1.4 GWe non-moderated thorium

VIII. MSR R&D INFRASTRUCTURES

molten-salt reactor (MSFR) [3] address the concept of large power units with a fast neutron spectrum in the core. In both designs fuel salt based on fluorides heats up in the core above 700°C before being cooled down in the heat exchangers. Third concept has been under development by TerraPower Inc: the “molten chloride fast spectrum reactor” (MCFR). It represents the first US Government funding for a liquid-fueled MSR in 40 years. The MCFR is intended to have a very hard neutron spectrum to avoid requiring fissile material input after its initial core load or separation of fissile materials from the remainder of the fuel salt.

Fast MSRs have large negative reactivity coefficients, a unique safety characteristic not found in solid-fuel fast reactors. Compared with solid-fuelled reactors, these systems have lower fissile inventories, no radiation damage constraints on attainable fuel burnup, no used nuclear fuel, no requirement to fabricate and handle solid fuel, and a homogeneous isotopic composition of fuel in the reactor.

Although the different MSRs concepts interests are focused on different baseline concepts, large commonalities in basic R&D areas exist and the GIF framework is useful to optimize the R&D efforts and infrastructures. The main MSR R&D challenges as identified in the 2014 Roadmap Update were:

- Compatibility of salts with structural materials for fuel and coolant circuits, as well as for fuel processing components. This challenge is addressed through academic lab-scale studies aiming to improve the basic knowledge on available high nickel alloys and other advanced materials, as well as through integrated corrosion studies in loops or demonstrator facilities aiming at testing the same materials under realistic conditions and for long exposure times.
- Instrumentation and control of liquid salts. This challenge requires the development of insitu measurement methods and tools to monitor the redox potential that impacts the corrosion of the structure materials in both the fuel and coolant salts.
- Comprehensive understanding of the key physical and chemical properties of the salts impacting the behavior of the fuel and coolant salts and, notably, the coupling mechanisms between neutronics, thermal hydraulic and chemistry. This understanding is of paramount importance for the development and qualification of appropriate simulation tools to study normal and accidental MSR behavior.
- Development and demonstration of on-site fuel processing concepts.
- Availability of inactive-salt testing loops. Such facilities are needed to support salt preparation and handling studies, chemical control, accidental leak and freezing management, validation of thermal hydraulics models, process instrumentation, components testing (including heat exchanger, pump, valves etc.), gaseous and volatile fission product and particle behavior and separation. Both forced and natural convection loops have to be considered to better understand heat and mass transfer and material long time exposure to fuel and coolant salts.
- Design, construction and operation of a mock-up demonstrator without induced fission capable of full-scale prototypic reactor components testing.
- Availability of a demonstrator with induced fission for in-pile and on-line chemical potential control, monitoring of the evolution of the salt composition, measurement of corrosion in a neutron field, fission product removal through helium bubbling in a fuel salt environment, as well as testing of maintenance techniques.

When reviewing the major achievements in response to these challenges, it must be noted that in spite of an increase in private initiatives, MSRs suffered from a lack of public funding that curtailed the volume of R&D work within the GIF framework and slowed down its pace. Therefore, the

VIII. MSR R&D INFRASTRUCTURES

aforementioned challenges could be tackled only partly. Progress achieved on the last three challenges described above is summarized in the following.

In CNRS, France the SWATH-W and SWATH-S facilities were designed and commissioned to investigate salt heat transfer and phase change phenomena. Helium bubbling and liquid – gas separation tests have been performed in the FFFER facility. The data will be used to improve numerical models used for molten salt design and safety studies [4].

An electrically heated and thermally insulated, forced convection FLIBE loop was built and commissioned in the Research Centre Řež [5]. The loop is intended for MSR and FHR material research and components testing.

The liquid salt test loop (LSTL) was created at the ORNL [6]. It is a versatile facility in support of the development and demonstration support development and demonstration FHR components. Recently, three US Vendors Have Announced Plans for Commercial US MSR Deployment by 2030s:

TerraPower	Kairos Power	Terrestrial Energy USA
<ul style="list-style-type: none"> •Separate effects tests (now) •Integrated effects test (2019) •Test reactor – 30-150 MWt – Class 104 License (2023-2028) •Commercial prototype reactor – 600-2500 MWt – Class 103 License (early 2030s) 	<ul style="list-style-type: none"> •Pre-conceptual design – March 2018 •Conceptual – December 2020 •Preliminary – Before 2025 •Detailed – Before 2030 •US demonstration by 2030 •Rapid deployment ramp up in 2030s 	<ul style="list-style-type: none"> •Conceptual design – mid-2016 •Vendor phase 1 design review (Canada) – October 2017 •Vendor phase 2 design review (Canada) – 2020 (starting 4Q2018) •Commercialization before 2030

Table VIII-2: Table of MSR SMR schedule

Finally, existing test loops and loops being constructed within the framework of the TMSR program in SINAP, China are establishing an important experimental complex in support of future R&D on MSR. The test reactor facility 2MWt TMSR-LF1 (LiF-BeF₂-ThF₄-UF₄ fuel salt, thermal neutron spectrum) was designed (and is currently under construction in Wuweu site, China, Fig VIII-1) within the framework of the TMSR program [7]. The reactor is scheduled to reach criticality in 2021 using existing TMSR funds.

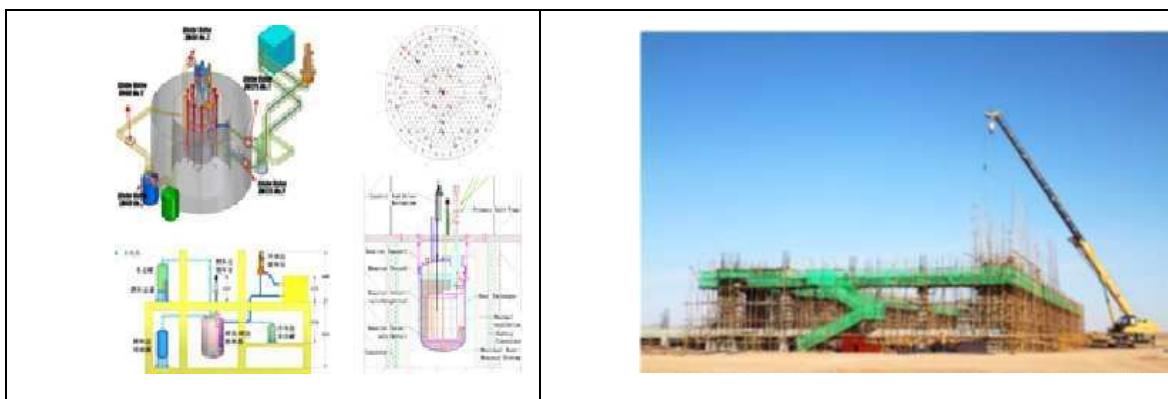

Figure VIII-2: Test TMSR-LF1 reactor under construction in Weweu, China

As applied to MSFR the irradiation experiments SALIENT-01 (SALt Irradiation ExperimeNT) of small $78\text{LiF}\cdot 22\text{ThF}_4$ salt samples in graphite crucibles was planned and is being currently conducted at HFR Petten. SALIENT-03 experiment with Li,Th,U,Pu/F salt and Hastelloy N and GH3535 alloy specimens is scheduled for Q4 2019. In parallel, a concept design was developed for a 125 kW (fissile) molten salt loop driven by neutrons from the HFR Petten as a demonstrator for in-pile performance of an integrated system.

The MSR development needs for the 2018 + 10 years period can be expressed in terms of the following grand challenges:

- Identifying, characterizing, and qualifying successful salt and materials combinations for MSRs.
- Developing integrated reactor performance modeling and safety assessment capabilities that capture the appropriate physics and fuel chemistry needed to evaluate the plant performance over all appropriate timescales and to license MSR designs.
- Demonstrating the safety characteristics of the MSR at laboratory and test reactor levels.
- Establishing a salt reactor infrastructure and economy that includes affordable and practical systems for the production, processing, transportation, and storage of radioactive salt constituents for use throughout the lifetime of MSR fleets.
- Licensing and safeguards framework development to guide research, development and demonstration.

REFERENCES

- [1]: Serp, J., et al., *The molten salt reactor (MSR) in Generation-IV: Overview and perspectives*, *Progress in Nuclear Energy*, 77, November, (2014) 308-319, <https://www.sciencedirect.com/journal/progress-in-nuclear-energy>
- [2]: Ignatiev, V., et al., *Molten salt reactor as necessary element for closure of the nuclear fuel cycle for all actinides*, *Atomic energy*, 122 (5), (2018) 250-253
- [3]: Dolan, T., “*Molten salt reactor and thorium energy*”, WP, Elsevier (2017)
- [4]: Allibert, M., et al., “*Chapter 7 - Molten Salt Fast Reactors*”, *Handbook of Generation-IV Nuclear Reactors*, Woodhead Publishing Series in Energy (2016)
- [5]: Uhlir, J., et al., “*Current Status of Experimental Development of MSR and FHR Technologies*”, *Transactions of the American Nuclear Society*, 117, (2017) 1105
- [6]: Yoder Jr., G.L., et al., “*An experimental test facility to support development of the fluoride-saltcooled high-temperature reactor*”, *Annals of Nuclear Energy*, 64, February (2014)
- [7]: Kun Chen, “*Development and licensing of a molten salt test reactor, TMSR-LF1*”, In *Proc. of GIF Symposium – Paris (France) – 16-17 October 2018*.

IX. CROSS-CUTTING R&D INFRASTRUCTURES

In support to the development of Generation-IV systems, the Task Force benefits from GIF Member State's latest relevant updates concerning R&D technical areas and facilities available.

IRRADIATION FACILITIES [Ref. 1 to 15]

MATERIALS TESTING REACTORS (MTR) R&D have proved to be an essential tool for fundamental research, providing representative conditions in nuclear power reactors, such as strong radiation, high temperature and pressure, and resistance of fuels and structural materials. Many powerful MTRs are still in use today, even though they started their operation in the late 1950s and 1960s. Reactors built in the 1970s include some specialized reactors such as: CABRI (FR), NSRR (JP), IGR (KZ), TREAT (US), and BGR (RU) for power pulse reactivity insertion accident (RIA) mode of testing.

Considerable experience with materials and fuels testing has been gained since the first MTRs, and a wealth of knowledge on materials and fuels behavior has been documented through ever more sophisticated experiments. Research has helped to answer many questions, but new ones continue to emerge. Growing safety criteria and new regulatory safety requirements place greater demands on materials and fuels, which in turn places evolving demands on safety regulation. Innovative Nuclear Generation-IV systems bring new requirements and conditions not yet experienced on an industrial scale.

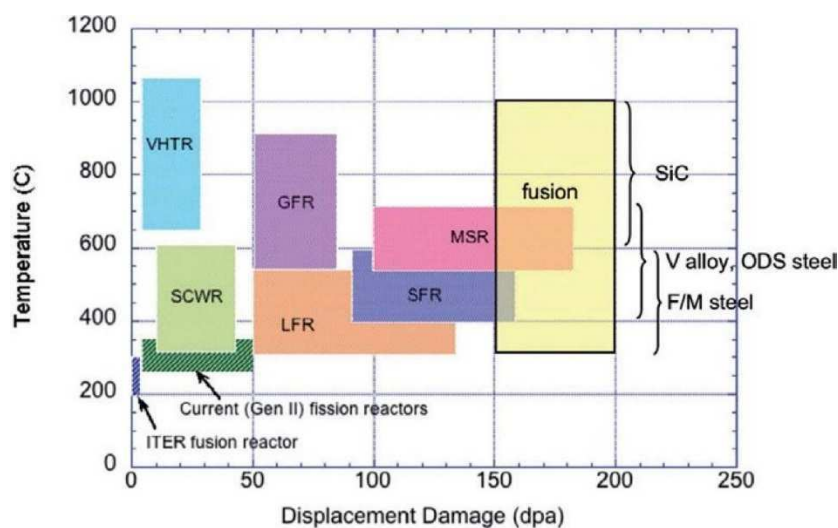

Figure IX-1: Requirements on materials in future Nuclear Energy Systems, Note: F/M = ferritic/martensitic; GFR = Gas Fast Reactor; ITER = International Thermonuclear Experimental Reactor; LFR = Lead Fast Reactor; MSR = Molten Salt Reactor; ODS = Oxide Dispersion Strengthened; SCWR = SuperCritical Water Reactor; SFR = Sodium Fast Reactor; VHTR = Very High Temperature Reactor.

R&D is generally focused on advanced materials research, which includes the testing of advanced fuels and structural materials (e.g. structural materials for liquid metal reactors or molten salt as a fuel), studying minor actinides and long-lived fission products burnout as well as exploring the extension of fuel resources, fuel cycle options and technologies. Existing and planned MTRs have, or will have, capacities to perform a broad spectrum of R&D aimed at developing innovative reactors like those being developed through the GIF and in Member State national programs.

IX. CROSS-CUTTING R&D INFRASTRUCTURES

RESEARCH REACTORS SUPPORTING INNOVATIVE NUCLEAR ENERGY SYSTEMS can be categorized according their power levels (High power (≥ 20 MW), Medium power (5–20 MW), Low power (< 5 MW)), mode of operation (steady state and pulsed reactors) and neutron spectrum (thermal and fast).

Most research reactors are designed for operation in steady state. Some of them have capabilities to implement relatively fast power transients, for example as required for ramp testing of fuels, and to subject fuels to simulated accident conditions, for example loss of coolant accident (LOCA) or power pulse reactivity insertion accident (RIA) mode of testing.

Fewer than 10 MTRs are pulsed systems. Pulsed reactors have unique capabilities to support fuels testing by addressing very fast transient accident scenarios, in particular RIA. Pulsed reactors can be utilized for testing the behavior of reactor fuel in design extension conditions (DECs) in order to define the safety limits for the design basis accident. Pulsed research reactors ensure a controllable, predefined energy release to simulate accidents on fuels and thus demonstrate safety parameters of new nuclear fuels designed for existing commercial reactors and for innovative Nuclear Energy Systems. Testing the nuclear fuel in DEC conditions is not yet a requirement, but the nuclear community anticipates a trend towards adopting such a standard. Design basis and DEC testing will continue to be coupled with engineering judgement, utilization of computer simulation codes and demonstrated operational experience. The testing programs, including irradiation and post-irradiation activities, will produce data which should enable justified judgements on the safety as well as economic efficiency of future Nuclear Energy Systems.

The majority of existing MTRs can serve current materials testing needs of thermal spectrum reactors as well as Generation-III/III+ reactors, which are based on present LWR technology.

Although some current and planned research reactors with high power density cores are able to provide locally a high fast neutron flux, their natural neutron spectrum differs from those foreseen in the context of Generation-IV development, with the exception of the supercritical water-cooled reactor and the high temperature reactor. Flux tailoring and trapping can be applied to come closer to the spectrum of metal cooled and molten salt reactor types, and Jules Horowitz Reactor (JHR) is designed with an under moderated core in order to support a high level of fast flux and less thermal spectrum in the core itself.

Eventually, research reactors specifically designed to serve the needs of next generation reactors will have to be considered, and prototype reactors need to be designed to include ancillary systems for materials and fuels testing. In the meantime, existing MTRs are a necessary and acceptable compromise. They can be made suitable for many types of investigation with the installation of appropriate experimental devices and systems.

Today, there are very few options for fast spectrum reactor research: BOR-60 and CEFR are currently operating; JOYO is planned to restart. Some major Generation-IV reactor designs plan to use non-water coolants (e.g. liquid metal and gas). These designs create technical demands concerning materials and fuels qualification leading to some very challenging R&D. In particular, the damage to material is quite high compared to thermal reactors, and consequently it requires research reactors with fast spectrum and high displacement per atom (dpa) rates (15–50 dpa/year). Worldwide, there is limited experimental capacity with the ability to deliver the required spectrum and corresponding dpa levels.

IX. CROSS-CUTTING R&D INFRASTRUCTURES

The accumulated material damage, measured in dpa, is proportional to the product of fast flux and irradiation time. BOR-60 currently provides the highest dpa (up to 25 dpa/year) and has many available cells with a very high flux and fast spectrum. Therefore, it is possible to provide massive testing of core materials and fuels in this reactor. CEFR has recently started its operation, and JOYO will provide similar capabilities when restarted.

Thermal spectrum reactors can also provide high dpa (up to 10–25 dpa/year): SM-3 (RU), HFIR (US), HFR (NL) and JHR (FR) in the future. However, the available volume and cells with highest flux in these reactors are limited, and these are typically accompanied by high gamma heating rates, which can pose challenges to sample temperatures. The JHR core has a design that permits an under moderated spectrum with some in-core location of hard neutron spectrum. In such a location, it will be possible to investigate Generation-IV type fuel and materials behavior in some dedicated loops (targeting a maximum of 16 dpa/year in some core positions). It is possible to achieve 14 dpa/year in HFIR and 25 dpa/year in SM-3 for the capsule type irradiation experiments.

The Jules Horowitz Material Testing Reactor (JHR) currently under construction on the CEA Cadarache site, will be operated as an international user's facility for materials and fuel irradiations for the nuclear industry or research institutes. It is also dedicated to the medical radio-isotopes production. The construction is made within the framework of an international consortium: CEA, EdF, FRAMATOME, Technicatome (France); European Commission with JRC as Observers; CIEMAT (Spain); SCKCEN (Belgium); VTT (Finland); UJV (Czech Republic); Studsvik (Sweden); NNL (UK); DAE (India); IAEC (Israel). The design of this facility allows a large flexibility in order to comply with a large range of experimental needs, regarding the type of samples (fuels or materials), neutron flux and spectrum, type of coolants and thermal hydraulics conditions (LWR, Gen-IV,...), in accordance with the scientific objectives of the programs for the next 60 years. The facility is a 100 MWth pool type reactor with a compact core (60cm fissile length, 70 cm diameter) cooled by a slightly pressurized primary circuit. The nuclear facility comprises a reactor building with all systems dedicated to the reactor and experimental devices; and an auxiliary building dedicated to tasks in support for reactor and experimental devices operation (hot cells, storage pools, laboratories). The design of the core provides irradiation cavities:

- 7 of small diameter; 3 of large diameter located in the core with a of a high fast neutron flux ($5,5 \cdot 10^{14}$ n.cm⁻².s⁻¹ above 1MeV corresponding to 16 dpa/year),
- about 20, most of them of 100mm diameter located in the Beryllium reflector zone surrounding the core, with a high thermal neutron flux (up to $3,5 \cdot 10^{14}$ n.cm⁻².s⁻¹), corresponding to about 0,1 dpa/y,
- Four to six water channels through the reflector equipped with displacement devices to control accurately the distance to the core and therefore the irradiation flux (for an accurate stable power, for power ramps, or for power cycling...).

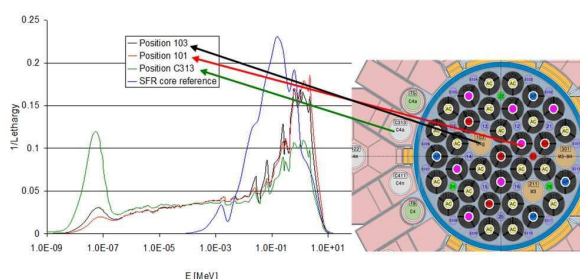

Figure IX-2: Neutron spectra in the JHR core.

IX. CROSS-CUTTING R&D INFRASTRUCTURES

For the future two main research reactor are under project or realization: MBIR (Russia) and VTR (USA). These two reactors are providing the most significant trust in irradiation means for the specific future needs a Gen-IV reactor systems.

Parameter / Loop name	LCh-Na	LCh-Pb	LCh-Pb-Bi	LCh-Gas (He)	LCh-Salt
Coolant	Sodium	Lead	Lead-bismuth alloy	Gas (high purity helium)	Metal fluorides melt
Neutron fluence in LCh, $cm^{-2}\cdot s^{-1}$	$\geq 3\cdot 10^{15}$	$2\cdot 10^{15}$	$(2\pm 3)\cdot 10^{15}$	$(0.4\pm 1)\cdot 10^{15}$	Up to $3.5\cdot 10^{15}$
Power, MW	Up to 1.0	≥ 0.3	Up to 0.8	Up to 0.15	Up to 0.15
External diameter, mm	≥ 190	≥ 190	≥ 190	≥ 130	≥ 150
Fuel length	MBIR core height	MBIR core height	MBIR core height	Side reflector height	MBIR core height
T_{in}/T_{out} of working fluid, $^{\circ}C$	320/550	Up to 350/ up to 750	Up to 350/ up to 500	≥ 950	750/ 800

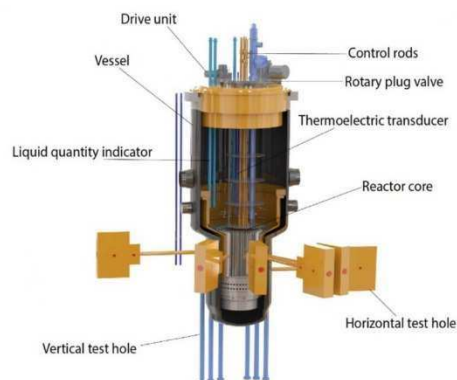

Figure IX-3: MBIR Independent loop channel parameters and cut-view

Parameter	Target
High neutron flux	$\geq 4 \times 10^{15} \text{ n/cm}^2\cdot\text{s}$
High fluence	$\geq 30 \text{ dpa/yr}$
High test volume in the core	$\geq 7 \text{ L}$ (multiple locations)
Representative testing height	$0.6 \leq L \leq 1 \text{ m}$
Flexible test environment	Rabbit & Loops (Na, Pb, LBE, He, Salt)
Advance instrumentation & sensors	In-situ, real time data
Experiment life cycle	Proximity to other infrastructure
Driver fuel life cycle management	Existing facilities as much as possible

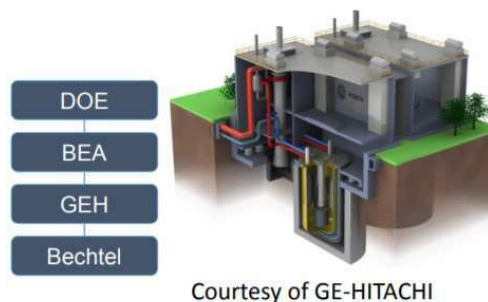

Figure IX-4: Preliminary requirements/assumptions for VTR (from [15])

LOW POWER RESEARCH REACTORS (<5 MW) can provide certain support for high flux irradiation facilities in a number of related applications. This feature can alleviate the general current underutilization of such low power facilities. Some complementary roles include the following: a) Instrument testing and calibration; b) Neutron irradiation testing by providing some basic damage information in well-defined neutron spectrum conditions, such as almost pure fission spectrum, on materials of interest for fission and on innovative nuclear fusion technologies; c) Nuclear data for cross-section measurements, integral experiments, benchmarking and code validation analyses; d) Nondestructive analysis, neutron radiography and other neutron beam techniques such as small angle neutron scattering and neutron diffraction are powerful tools for the non-destructive testing of materials. In particular, degradation phenomena in fissile and structural materials following high level neutron fluence irradiation in high power research facilities can also be investigated in low power research reactors (as well as in high power research reactors) using this technique, and theoretical models can be improved on the basis of the experimental results.

IX. CROSS-CUTTING R&D INFRASTRUCTURES

UNIQUE EXPERIMENTAL CAPABILITIES DUE TO CORE DESIGN exist as virtually all reactors have unique capabilities with regard to core designs. Throughout the reactor lifetime, many of these facilities have changed or modified their configurations in order to develop new testing capabilities. These reactors typically use plate type fuel. However, there are several variations on the plate fuel composition, and some also use rod fuels e.g. Advanced Test Reactor ATR (US), Belgium Reactor 2 BR2 (BE).

BALANCING EXPERIMENTAL VOLUME AND NEUTRON FLUX are generally speaking challenging as research reactors are compact machines compared to power producing reactors. This compactness can make experiment design very challenging, particularly for MTR type fuels and nonpin style targets, where full scale geometries may be necessary to test adequately fuel swelling and fuel-clad interactions. For sealed capsule experiments on materials, specimens can be easily packed into small capsules and placed at the optimal location in most reactors. Particularly with the advent of very small tensile specimen sizes, this has become a relatively routine task. For experiments requiring flow loops, irradiation rigs or larger sample sizes, the flux distribution becomes more important to the design of the experiment and may be a limiting factor for certain test samples.

QUALIFYING UNIQUE COOLANTS FOR INNOVATIVE GENERATION-IV REACTORS requires MTRs' research to optimize the reactor materials, with special attention to prospective coolants (e.g. heavy liquid metals, molten salts or supercritical water) and their interaction with in-core and primary circuit materials. Several current MTRs offer loops to create the thermos hydraulic conditions of various types of nuclear power reactor. There are plans to install such loops at other research reactors, for example JHR (FR) and CARR (CN). However, limited data on the coolants of next generation reactors are available. Plans exist for supercritical water loops whose design can rely on proven technologies known from LWRs and supercritical water fossil plants. Their application will be to identify and test materials that are resistant to corrosion and stress corrosion cracking in supercritical water conditions.

Currently, there are not any research reactors in operation that include in-core loops for molten salts or liquid metals. The operation of such loops will face the same problems that the research intends to solve. For example, the MIR.M1 lead-bismuth facility was in operation in the past, but currently it is in standby. A solution that is easier to implement, but which does not allow control of the chemistry, is the use of capsules with only internal circulation of the coolant. A number of MTRs have experience with such irradiation devices and loop experiments, although not necessarily with molten salts or metals in them: JMTR (water, JP), JOYO (sodium, JP), HANARO (water, KR), HFR (water, NL), TRIGA II Pitești (gas, RO), BOR-60 (lead, lead-bismuth, sodium, RU), RBT-6 (water, supercritical water, RU) and ATR (gas, US).

IN-CORE INSTRUMENTATION is essential for performance studies of materials and fuels, since it provides direct insight into phenomena as they develop and cross-correlations between them. The basic instrumentation for fuel behavior studies encompasses fuel thermocouples, rod pressure transducers for fission gas release assessment, fuel stack elongation detectors for measuring densification and swelling, and clad elongation detectors for axial pellet-clad mechanical interactions. Typical materials performance studies require the ability to measure crack initiation, crack growth and time to failure.

The conditions in the core of a research reactor are not conducive to instrument performance and the ability to survive for a long period of time. Instrument performance issues will be accentuated in

IX. CROSS-CUTTING R&D INFRASTRUCTURES

MTRs simulating next generation reactor conditions with even higher gamma fluxes (up to 15 W/g), higher neutron fluxes ($>5 \times 10^{14} \text{ n}\cdot\text{cm}^{-2}\cdot\text{s}^{-1}$), higher temperatures ($>600^\circ\text{C}$) and higher pressures ($>25 \text{ MPa}$), which can all contribute to instrument failure. Only robust instruments will endure in-core conditions for longer times, and this requires the development of more reliable instrumentation. Similar considerations apply to instrumentation in the coolant.

Instrument performance is an important topic for future experiments in MTR, as end users (e.g. fuel physicists and material scientists) require ever more on-line information for simulation of physics phenomena based on related computer codes.

This leads to some important R&D collaboration between research institutions, and on projects, in different countries, for example the Halden Reactor Project (to be decommissioned, NO); the Belgian Nuclear Research Centre (SCK•CEN, BE); the Idaho National Laboratory (INL, US); the French Alternative Energies and Atomic Energy Commission (CEA, FR); and the Research Institute of Atomic Reactors (RIAR, RU). Eventually, it will also lead to the arrival of new instrumentation for the next generation of experiments in MTRs, for example: sensors; thermocouple devices; enhanced linear voltage differential transformers; neutron fission chambers; radiation and temperature resistance video scopes; and ultrasonic transducers.

OUT-CORE INSTRUMENTATION: In this field several techniques could be common to the different reactor systems. For example acoustic techniques could respond to the needs encountered in the case of opaque heat extracting fluid or in the case of high pressure fluid where the use of transparent windows could be required. Then, many facilities can support the validation of the technology in representative conditions. Among the instrumentation, the use of optical fibres is of common interest for different kinds of systems. However, the behaviour of these optical fibres at high temperature and possible under irradiation has to be tested. To achieve this goal, oven and irradiation infrastructure are required. But another key point concerns the capabilities to produce specific optical fibres (such as Bragg ones) in a semi-industrial manner after specific doping or specific manufacturing procedures previous to the determination of their behaviour in irradiation conditions for example. In the field of repair techniques, the validation and qualification of the sensors carriers or the robotic arms is of major interest. For that, as most of the systems operate at high temperature, the use of large oven could be required.

CHARGED PARTICLE IRRADIATION FACILITIES can be electrons, protons or ions of different weight. Although the penetration of protons and light ions can be significant, all these particles are obviously efficiently stopped by electrons and ions inside the materials, thereby affecting only limited volumes, insufficient to produce standard specimens for e.g. mechanical property testing. Moreover, there are spectral differences with respect to neutrons in terms of damage that is produced and the progressive slowing down results in damage production gradients, while chemical species initially absent in the material and/or atoms in excess are injected in the target material, including sometimes unwanted impurities that are difficult to control, e.g. carbon. Despite these shortcomings and limitations, which certainly prevent their use for full qualification purposes, charged particle irradiation is useful to get insight into the behavior of materials under irradiation. A significant number of facilities permitting charged particle irradiation, which can be exploited for modelling and screening purposes.

JANNuS dedicated to the experimental simulation and fundamental knowledge of neutron damages in nuclear materials. Served by an experienced scientific staff, the JANNuS-Saclay facility consists of three electrostatic ion accelerators (respectively named Epimethee, Japet and Pandore)

IX. CROSS-CUTTING R&D INFRASTRUCTURES

connected to a triple beam end-station for single-, dual- and triple beam irradiations/implantations. Two other end-stations are linked to Epimethee and Pandore for single beam ion irradiation/implantations and/or Ion Beam Analysis. These particle beams make it possible to irradiate small samples in a perfectly controlled manner, and thus to observe and quantify the evolution of their microstructure (segregation, precipitation, dissolution, change in the dislocation network, formation of dislocation loops, cavities, bubbles, etc). Such a scientific platform plays an essential role for multi-scale modelling of radiation effects in materials.

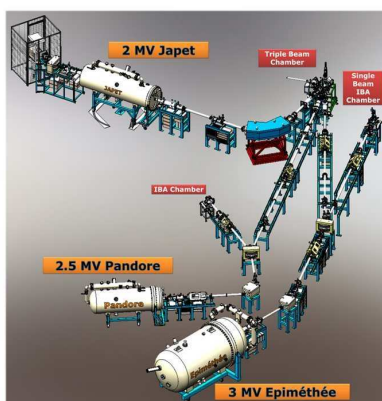

Figure IX-5: JANNUS facility artistic birdview

HANDLING OF IRRADIATED MATERIALS

PRE- AND POST-IRRADIATION HOT CELL FACILITIES are critical partners to current research reactors. Ideally, a research reactor site should provide laboratories to prepare and perform experimental research, workshops for designing and manufacturing experimental devices, for installations and for re-fabrication of experimental samples from irradiated materials and fuels. Hot cells and glove boxes for non-destructive and destructive Post Irradiation Experiments (PIEs) of irradiated materials and fuels should also be provided.

Limited availability of hot cell facilities, especially those licensed for fuel handling, limits enormously the number of tests, measurements and examinations that can be performed on irradiated fuels and materials. As a result, post-irradiation examinations of samples may take several years to be completed. This problem is ever exacerbated by rising costs, difficulties to transport irradiated materials, and use of advanced microstructural examination new techniques that did not exist when most hot cell facilities were built. Already insufficient today and, as they age further, their replacement will be imperative.

Hot cell facilities include mainly PSI-hot cells (Switzerland), FHL (NDC) and NFD hot cells (Japan), IMEF (Korea), Chalk River Lab (Canada), RIAR (KI) (Russia), Argonne National Laboratory (USA), Oak Ridge National laboratory (USA), Hot cells (Czech. Rep.), Idaho National Lab. (USA), CEA LEFCA and ATALANTE facilities for minor actinide bearing fuels fabrication and fuel recycling (France), and EC-JRC ITU (Germany).

As an illustration, in the U.K., there are hot cells and flexible PIE capabilities which can handle a wide range of materials and fuel types at NNL. There is also extensive investment in new materials facilities (DCF, MRF, ROYCE and NNUF) which will provide a wide range of relevant microstructural capabilities. For instance there will be a rig for high temperature mechanical testing of active samples

with μ XCT/Diffraction available at the Diamond Synchrotron (which will be relevant to graphite testing for VHTR and GFR), ROYCE is building alpha active facilities at Manchester University which will be relevant for the fuel cycle of several Gen-IV designs and there are plans to build a thermal hydraulic research and testing facility in North Wales.

NUCLEAR DATA MEASUREMENTS [Ref. 16 to 18]

Advances in the development of nuclear science and technology require highly accurate, powerful simulations and precise analysis of the experimental results. Safety confidence in these results is still determined by the accuracy of the atomic and nuclear input data. For studying material response, neutron beams produced from accelerators and research reactors in broad energy spectra are reliable and indispensable tools to obtain high accuracy experimental results for neutron induced reactions. The nuclear data community gathers infrastructures and resources to prepare the methodologies, detectors, facilities, interpretation and tools to produce and use nuclear data (mainly different cross sections), to comply with the needs for the safety standards mandatory for present and future nuclear reactors and other radioactive installations. OECD/NEA Nuclear Science Committee's Working Party on International Nuclear Data Evaluation Cooperation (WPEC) promotes the exchange of information on nuclear data measurements, model calculations, evaluation work and validation. OECD/NEA's nuclear data evaluation co-operation activities involve the following evaluation projects: ENDF (United States), JENDL (Japan), ROSFOND/BROND (Russia), JEFF (Joint Evaluated Fission and Fusion, other Data Bank member countries) and CENDL (China) in close co-operation with the Nuclear Data Section of the International Atomic Energy Agency (IAEA).

ADVANCED MODELLING, SIMULATION TOOLS AND DIGITALISATION [Ref. 19 to 20]

Considering modelling and simulations, the general trend can be summarized as multi-scale, multi-physics, multi-phase and quantification of uncertainties. Driven by progress in computational power and increasing understanding of separate processes, state-of-the-art computer codes and computational simulation platforms are essential tools for the competitiveness of the nuclear industry and improved cooperation between partners, as it is for other industrial sectors such as aerospace or automotive. Advanced modelling, simulation tools and digitalization three main goals are : a) to adapt and to accelerate the coupling between existing calculation codes by improving interoperability; b) to unify and make consistent numerical applications by linking the world of advanced expertise studies and industrial modelling; c) to benefit from breakthroughs in advanced visualization technologies (including virtual reality and augmented reality); and d) to provide highly attractive e-infrastructures and e-learning platforms e.g. supporting GIF Members States, OECD/NEA and IAEA initiatives, and establishment of a virtual research reactor laboratory.

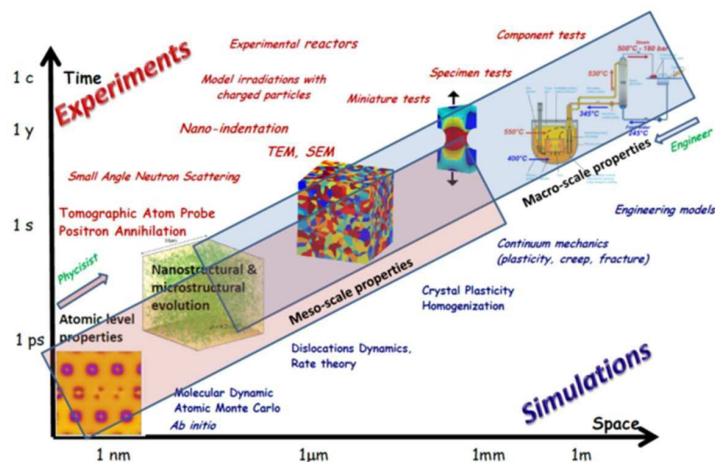

Figure IX-6: Modelling and experimental characterization techniques at various time and length scales involved in the ICME approach, to elucidate the mechanisms of nuclear material behavior and their coupling.

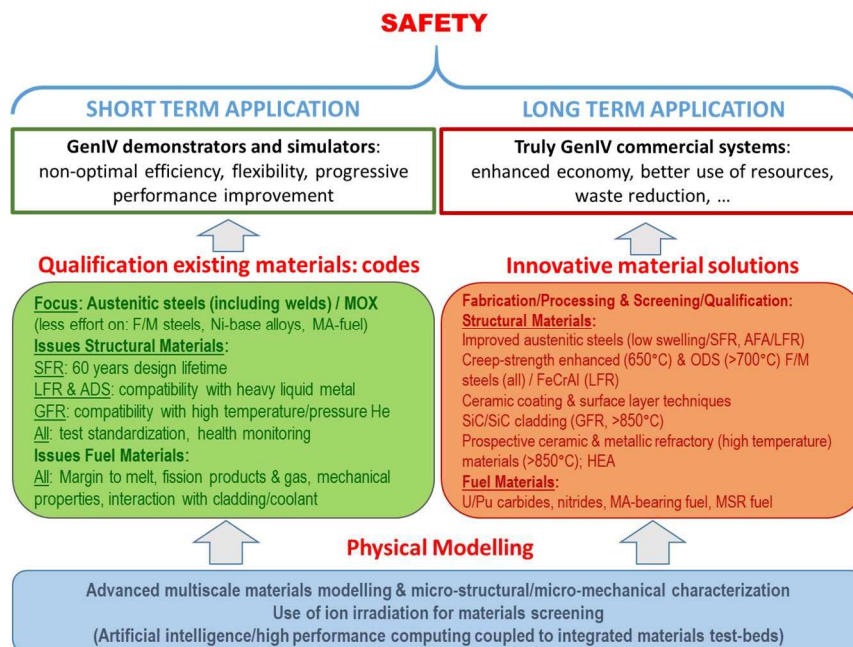

Figure IX-7: The two parallel paths followed in the present EERA-JPNM Strategic Research Agenda, one (left line) with short-term and the other one (right line) with long-term perspective

Even if the need for computing facilities is not specific to the investigation of nuclear fuels, materials, and thermal-hydraulics, it is worth stressing that the Integrated Computational Materials Engineering (ICME) approach as well as the simulations using design and fuel performance codes, are computationally intensive and call for access to world-class high-performance computing (HPC) systems for science and engineering. Industry and Small and Medium Enterprises are increasingly relying on the power of supercomputers to come up with innovative solutions, to limit the need of experimental validation, to reduce cost and decrease time to market for products and services. This is a foremost condition for advanced modelling to bring the appropriate support to the development and qualification of the materials and fuels needed for Generation-IV systems.

IX. CROSS-CUTTING R&D INFRASTRUCTURES

Thanks to computing exceptional performances, the level and number of experimental facilities has been drastically reduced compared to the reactors development in the 80's. But it is a dream to believe that thank to computing the need for experimental facility will come to nil. Indeed, the use of computing codes and modelling requires at the same time Codes validation and verification and Uncertainties quantification. In addition, Safety Authorities are asking for more detailed and accurate data which require fine meshing. And it is still necessary to demonstrate how far you can rely on your codes and modelling systems. So the scientific community is going towards less experimental tests, but for more Code benchmark and code validation and verification. Therefore, the **integral** replacement of experimental data by code simulation remains an utopia. G. Gaillard-Groleas is providing a clear explanation of this position: the Verification/Validation and Uncertainty Quantification (VVUQ) approach is carried out in three steps (see figure below).

Approach required to meet the regulatory requirements

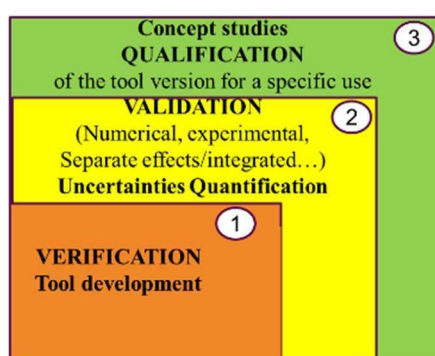

VVUQ approach: steps 1 and 2

(Verification/Validation and Uncertainty Quantification)

Figure IX-8: The VV&UO approach defined in three steps (French approach)

The Step 1 is Subsequent to the Code Development. This Verification step ensures that the resolution of the equations is correct, that the calculation tool works as expected (correct digital implementation, correct numerical solution).

Step 2 is the Validation and uncertainties quantification. The validation is to ensure that the mathematical model developed for the calculation of physical phenomena has the ability to represent them properly in an identified domain. The validation phase involves comparing the results of the simulation tool to experimental data coming from mock-ups and/or reactor operation feedback, as well as to already qualified calculations (benchmarking). The validation must prove the relevance of the tests and physical phenomena analyzed and there is a need of the identification of the influential parameters on the major physical phenomena. At this stage the Simulation tool is « ready to be used » with respect to its manual guide, validation domain, computing environment... The tool is available for teams driving the selection process of the design options and the safety studies of the concerned reactor study.

Step 3 is the Qualification step. Its goal is to ensure the validity, the relevance of the obtained results. And also to demonstrate the quality of, and the confidence in provided results. This step must principally ensure the adequacy of the validity domain of the tool with the study using it. The tool must be used in the domain where it is supposed to be valid and the proof of this verification must be provided. The role of application and validation domains analysis is to decide whether a code may be used: to compute quality-controlled industrial applications, or with caution considering specific physics, or only

after working further on validation. This step is a key point in accepting studies dedicated to the safety demonstration.

A European reference simulation platform NURESIM (Nuclear Reactor SIMulation) was developed for more than a decade with a significant support from different Euratom projects (NURESIM, NURISP, NURESAFE, HPMC, McSAFE, ...). This platform includes advanced core physics, two-phase thermal-hydraulics, fuel modelling, verification and benchmarking, Monte Carlo codes, multi-scale and multi-physics features together with sensitivity and uncertainty tools. These physics are validated and fully integrated into the platform using the open-source software SALOME, in order to provide a standardized state-of-the-art code system to support safety analysis of current and evolving LWRs, simulation of normal operation and design basis accident. As the basic physics in thermal-hydraulics, fundamental conservation equations of mass, momentum, and energy, and the numerical methods and models to solve these questions, is valid for both water and liquid metals, a lot of experience can be shared between the light water thermal-hydraulics community and the liquid metal thermal-hydraulics community. Multi-scale code development, maximum use will be made of synergy between the LWR developments in a project on 'thermal hydraulics Simulations and Experiments for the Safety Assessment of METal cooled reactors — SESAME'. NURESIM includes a comprehensive capability for uncertainty quantification, sensitivity analysis and model calibration provided by the URANIE open-source software. [21 and 22]

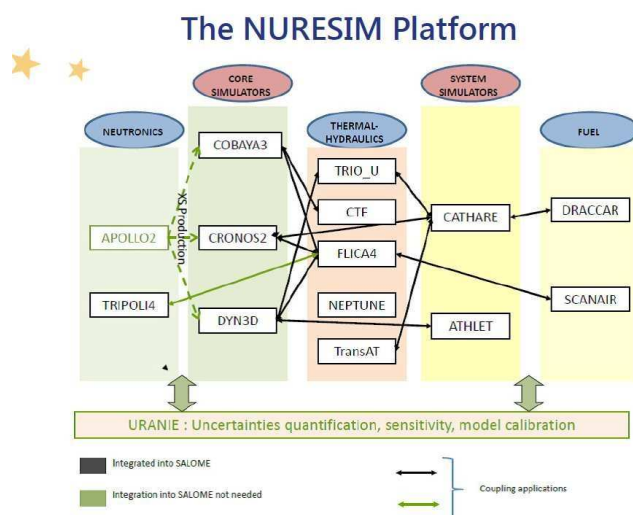

Figure IX-9: Overview of NURESIM platform and codes (Common generic tools, Reactor system simulators, Core simulators, Neutronics, Thermal-hydraulics, Fuel-Thermo-mechanics)

Idaho National Laboratory's MOOSE (Multiphysics Object Oriented Simulation Environment) now makes modelling and simulation more accessible to a broad array of scientists, in support of nuclear applications for DOE programmes e.g. Nuclear Energy Advanced Modeling and Simulation (NEAMS). MOOSE enables simulation tools to be developed in a fraction of the time previously required. It has revolutionized predictive modelling, especially in the field of nuclear engineering, allowing nuclear fuels and materials scientists to develop numerous applications that predict the behaviour of fuels and materials under operating and accident conditions. MOOSE-based software applications are in development for nuclear energy (radiation transport, reactor physics, nuclear plant safety and systems analysis, and multi-scale nuclear fuels performance), materials (fundamental materials development, effects of corrosion, damage and aging evolution, and irradiated material analysis), structural dynamics,

multi-phase flow, waste analysis, and geophysics (seismic, geothermal, geochemistry, and isotope transport). These MOOSE-based applications are assisting in designing and optimizing experiments both nationally e.g. with Advanced Test Reactor (ATR), Transient Reactor Test Facility (TREAT), and High-Flux Isotope Reactor (HFIR) at ORNL and internationally. [23]

At the end of 2019 the International Atomic Energy Agency (IAEA) launched a new initiative and an international platform aimed at promoting the development and application of open-source multi-physics simulation in support of research and development (R&D) and education and training (E&T) in nuclear science and technology (NS&T) [24]. As well known, advanced modelling and simulation is increasingly becoming a key tool in NS&T, including nuclear power. However, the access to the most advanced simulation codes to conduct R&D in support of innovative nuclear systems is sometimes limited by intellectual property rights. Open-source software and open-access data facilitate collaborative R&D while lowering the barriers associated to code distribution, modification, and sharing. The long-term goal of the IAEA initiative is the development of a consistent platform for nuclear reactor analysis available to the IAEA Member States. Currently, the just created international expert group composed of scientists from France, Germany, Italy, Switzerland, UK, USA as well as IAEA and OECD/NEA is concentrating its effort on:

- Creation of a list of available codes, including information on their application field, development status, contact institution, license, list of available of input decks, etc.;
- Creation of a list of open-access data and data repositories;
- Creation of a list of gaps in the available codes and data;
- Organization of topical meetings, including workshops, special sessions at conferences, roundtable discussions, as well as consultancy and technical meeting at the IAEA; -
- Organization of summer schools on modelling and simulation and on open-source tools.

HARMONISATION OF LICENSING RULES, CERTIFICATION, AND STANDARDS [Ref. 25-26]

Pre-normative research for new design and operating conditions, establishment of shared codes and standards with a strategy providing methods progressively enlarges consensus among stakeholders. This also includes a digital approach to nuclear, optimization of supply chain, mutual recognition by regulatory activities, streamlining of design approval and harmonized classification schemes.

Harmonization of procedures and methodologies are further needed to test and characterize materials, especially innovative materials in specific environments, including protocols to perform microstructural examination with advanced techniques and to analyze the results. In several cases, completely new tests need to be designed and standardized. Design codes such as the French Design and Construction Rules for Mechanical Components in high-temperature structures, experimental reactors and fusion reactors RCC-MRx (FR) and American Society of Mechanical Engineers Boiler and Pressure Vessel Code ASME BVP (US) Section III share the same goals, so also in this area there is mutual interest to share, compare and harmonize methodologies for design rules and design curves.

Increased cooperation between GIF Member States, public and private activities and investments involving industry, research centers, academia and technical safety organizations should be strongly promoted within international frameworks. It is essential to have early close links to industrial applications, even when Technology Readiness Level (TRL) 2 to 5 for fuels and materials are achieved, pre-normative R&D and robust qualifications enable then any industrial use.

EDUCATION AND TRAINING, KNOWLEDGE MANAGEMENT, MOBILITY AND ACCESS TO RESEARCH INFRASTRUCTURES [Ref. 27 to 30]

Generation-IV innovative nuclear reactors are very attractive to young students, scientists and engineers engaging in a nuclear career thanks to the related scientific challenges characterized by higher operating temperatures, studies on high temperature materials, corrosion effects, heavy liquid metal thermodynamics, innovative heat exchangers, fast neutron fluxes for breeding and enhanced burning of long-lived wastes. Development, fabrication and testing of entirely new nuclear fuels, advanced fuel cycles, fuel recycling concepts including partitioning and transmutation are required, all promoting excellent topical opportunities for internships, post Doctorate or PhD studies within R&D laboratories. Beyond the obvious educational merit for young engineers investing on average into additional two to three years' fast reactor studies, scientists and engineers would also have a broader expertise when working on enhanced LWR technology and cross-cutting safety, core physics, engineering and materials areas. Also, a successful Generation-IV design team would highly benefit from 'systemic' and 'interdisciplinary' specialists in the various scientific disciplines involved such as neutronics, thermal-hydraulics, materials science, coolant technologies together with 'assembling' engineers capable to perform optimized integrations of all topical results into 'realistic' reactor components and 'most efficient' civil engineering and balance of plants. A suitable and inherently attractive Education and Training (E&T) program is therefore required to reduce the significant and long-lasting risk of a shortage of nuclear skills and ensure the maintenance of the acquired knowledge and expertise.

Today's Research Infrastructures include major scientific equipment, scientific collections, structured information, ICT-based infrastructures, they are single sited or distributed throughout several countries. GIF Member States are faced with a wide spectrum of issues, from infrastructures which are globally unique to many regionally distributed. Many stakeholders are involved, from ministries to researchers and industry, with an underlying and growing use of e-infrastructures. They are opportunities but also difficulties of interaction between basic research and industry, public and private funding is always lacking (or at the minimum complicate to put in practice), and single countries do not usually have the critical mass or the dimension to implement large scale research or experimental infrastructures. Many research reactors face issues and challenges such as:

- ageing management (50% of the facilities are older than 40 years),
- ageing of personnel, and lacking of turnover. Indeed, it is still difficulty to attract young generation people in these jobs, because long duration of skills acquisition can discourage them. In addition it is still difficult for operators to move from non-nuclear industry to nuclear industry because of the same limiting factors. Sometimes the uniqueness of a specific facility is making much more difficult the operator turnover and can discourage young operators: a too much specific facility can be considered as a dead-end situation for personal carrier,
- underutilization (50% of the facilities are operated for less than four full power equivalent weeks per year), a lack of clear purpose and mission (and often changing when the nuclear community is seeking for long term vision), limited budgets, and the need to address reactor safety and security. Underutilization does not however affect most MTRs, which usually have a higher utilization factor of up to approximately 70% (250 full power days per year).

GIF Member States, OECD/NEA or IAEA, all have a long-standing experience in co-founding collaborative research programs with the participation of public/private consortia, following competitive call for proposals or on an ad-hoc basis. GIF MS provide support to researchers and integration of activities in a closely coordinated manner: a) Networking activities, to foster a culture of cooperation between research infrastructures, scientific communities, industries and other stakeholders

IX. CROSS-CUTTING R&D INFRASTRUCTURES

as appropriate, and to help develop a more efficient and attractive framework; b) Transnational access or virtual access activities, to support scientific communities in their access to identified key research infrastructures; and c) Joint research activities, to improve, in quality and/or quantity, the integrated services provided at international level by these infrastructures.

The total number of research reactors will continue to decrease. New powerful (and therefore expensive) research reactors will need to be considered in a cooperative and consolidated manner, and should be proposed as shared user facilities among interested international partners. The future of existing and planned MTRs will strongly depend on international cooperation and willingness of Member States to open these facilities to international use. This objective is realized through the cooperation between universities, research organizations, regulatory bodies, industry and any other organizations involved in the application of nuclear science, and supporting international mobility of young scientists or researchers, mutual recognition of competences, giving overall a new impetus, high incentives and perspectives for E&T within Europe and Internationally. In this context, the IAEA International Center of Excellence of Research Reactors (ICERR) or USA Nuclear Science User Facility (NSUF) schemes are promising possibilities to address the challenges of present and future MTRs.

As an illustration, France is providing an important nuclear teaching platform organized around engineering schools, universities, research laboratories, technical schools but also nuclear companies or dedicated entities for professional training. Within this context, the Institut National des Sciences et Technologies Nucléaires (INSTN), with its own Nuclear Engineering Master level (or specialization) degree and a catalogue of more than 200 vocational training courses, is one of the major nuclear E&T operators in Europe.

In Belgium, SCK•CEN Academy for Nuclear Science and Technology was established at the beginning of 2012 benefitting from sixty years of research into peaceful applications of nuclear science and technology, material and fuel research performed today at the BR2 reactor. With such an extensive experience and involvement in the development of an innovative Multipurpose hYbrid Research Reactor for High-tech Applications (MYRRHA), major nuclear installations and specialist laboratories are available today on site, SCK•CEN is well placed to take on the role of an international education and training platform on Heavy Liquid Metal (Pb-Bi). In addition, IAEA and SCK•CEN Academy have agreed in 2015, CEA-INSTN and SCK•CEN have also signed in September 2016 cooperation framework agreements on E&T.

EU/Euratom Education and Training initiatives are increasingly being organized with the support of the European Commission to the European Nuclear Education Network (ENEN): Workshop with dedicated Young Generation Event, Summer School...

ADVANCED SMALL MODULAR REACTORS (SMRs) OPPORTUNITIES [Ref. 31]

The past decade has seen the global emergence of nuclear reactor technologies that are designed as smaller and more flexible plants than the large 1,000-megawatt (or over) versions that currently dominate the baseload power landscape. These Small Modular Reactors (SMRs) will employ passive safety features, have fewer parts and components, operate with smaller nuclear cores (and thus smaller source terms), and leverage their modular design to be constructed faster and at less capital cost to the customer. SMRs are defined as power reactors up to 300 MWe, whose components and systems can be fabricated in a factory, and transported as modules to their designated sites for installation as demand arises. The most promising SMR designs adopt inherent safety features and are deployable either as a

IX. CROSS-CUTTING R&D INFRASTRUCTURES

single or multi-module plant. The key driving forces of SMR development are fulfilling the need for flexible power generation for a wider range of users and applications; for instance replacing ageing fossil power plants, providing the opportunity of partial or dedicated use in non-electrical applications such as providing heat for industrial processes, hydrogen production or sea-water desalination. Process heat or cogeneration results in significantly improved thermal efficiencies leading to a better and quicker return on investment. SMR could enable supply of energy to remote areas or developing countries with small electricity grids, and hybrid nuclear/renewables energy systems. Some SMR designs may also serve niche markets, for example to burn (or transmute) nuclear wastes.

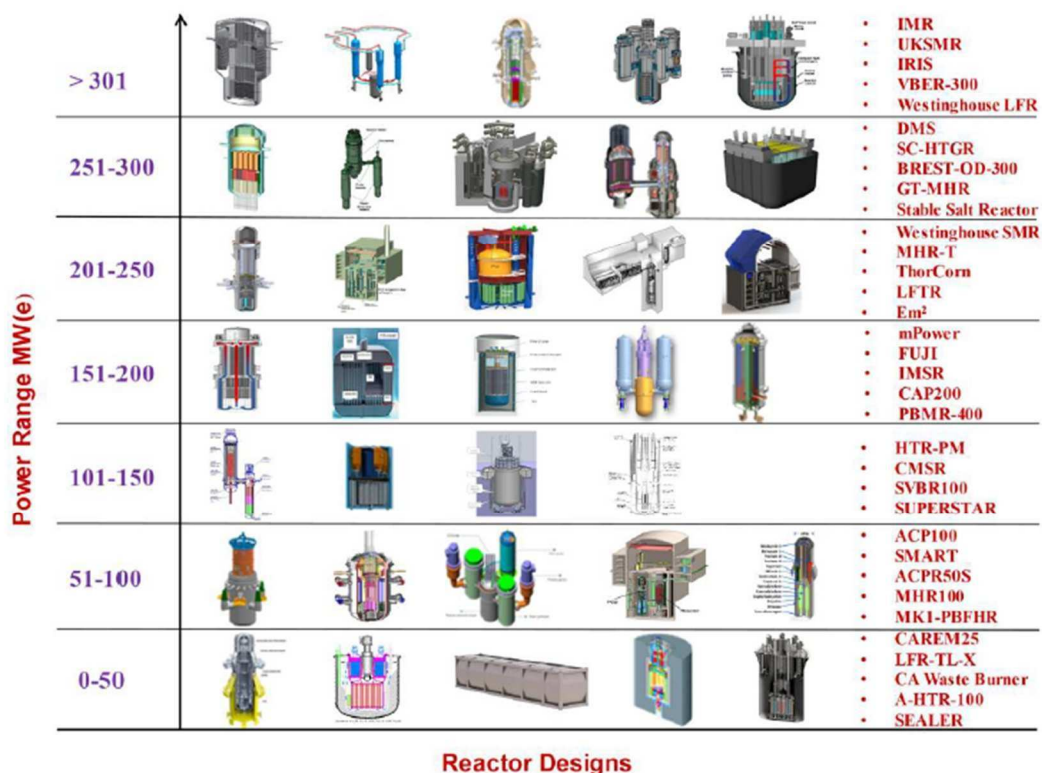

Fig IX-10: Summary SMR designs based on power range (IAEA 2018 SMR booklet)

Several GIF Member State Countries e.g. Russia, USA, China, France, UK have governmental strategies supporting the development of SMRs (mainly integral PWRs but also HTRs, LFRs, GFRs, MSR) with projects usually led by both public and private research centers, and industries, sometimes as a mix.

SMR R&D program objectives mainly are to: a) Finalize SMR designs (mainly PWRs technology) for commercial construction and operation; b) Improve SMR economic competitiveness; c) Support the development of a prototype SMR nuclear steam supply system; d) Support the deployment of the first commercial SMR series; e) Support the development of advanced manufacturing methodologies; f) Establish centers of excellence for advanced nuclear manufacturing; g) Prove out the supply chain; h) Align codes and standards and requirements, with SMR requirements; i) Gather regulators and licensing technical support for design certification, applications for an early site permit, and construction and operating license.

SMR support provided by the Regulators and Licensing Technical Support programs has generated significant partnerships momentum and opportunities in the industry. As an illustration, DOE's Gateway for Accelerated Innovation in Nuclear (GAIN) initiative was established to provide potential industry partners with opportunities to access the technical, regulatory, and financial support necessary to move innovative nuclear energy technologies toward commercialization. Opportunities include access to the unique capabilities of the DOE laboratory system to accomplish innovative research and development projects that can more efficiently and quickly bring these concepts to market.

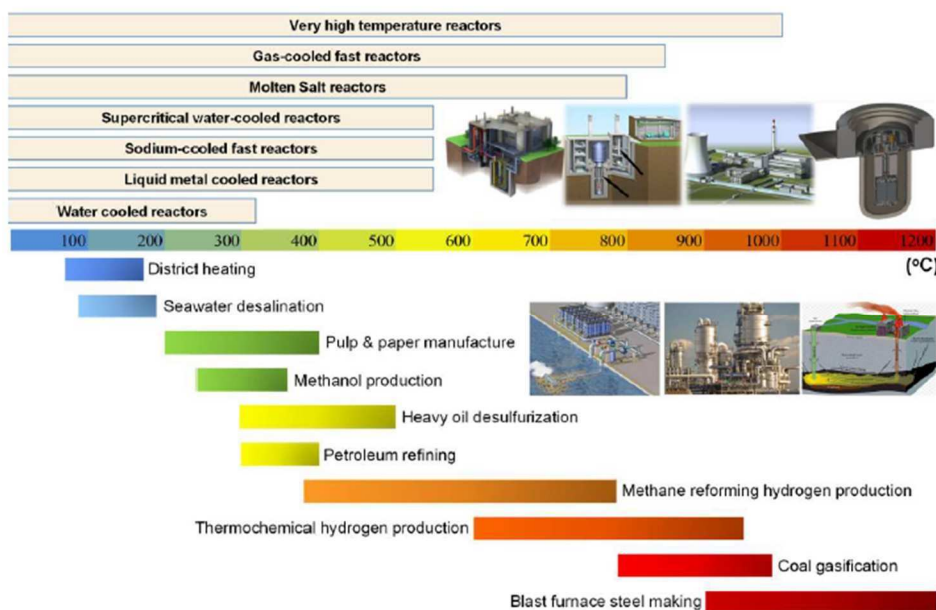

Figure IX-11: Summary of SMR designs for non-electric applications (IAEA 2018 SMR booklet)

REFERENCES

- [1]: IAEA database of Facilities in Support of Liquid Metal-cooled Fast Neutron Systems Facilities <https://nucleus.iaea.org/sites/lmfns/Pages/default.aspx>
- [2]: IAEA Advanced Reactor Information System (ARIS) <https://aris.iaea.org/>
- [3]: IAEA Research Reactor database (RRDB) <https://nucleus.iaea.org/RRDB/RR/ReactorSearch.aspx>
- [4]: IAEA Research Reactors for the Development of Materials and Fuels for Innovative Nuclear Energy Systems, No. NP-T-5.8, <https://www.iaea.org/publications/10984/research-reactors-for-the-development-of-materials-and-fuels-for-innovative-nuclear-energy-systems>
- [5]: OECD/NEA Research and test facilities database (RTFDB) <https://www.oecd-nea.org/rtfdb/>
- [6]: OECD/NEA Task Group on Advanced Experimental Facilities (TAREF) on SFR <https://www.oecd-nea.org/globalsearch/download.php?doc=77089> and GFR/HTR <https://www.oecd-nea.org/globalsearch/download.php?doc=8901>
- [7]: OECD/NEA Task Group on Support Facilities for Existing and Advanced Reactors (SFEAR), 2007, <https://www.oecd-nea.org/globalsearch/download.php?doc=6450>
- [8]: EU/Euratom Sustainable Nuclear Energy Technology Platform (SNETP) Strategic Research and Innovation Agenda (SRiA), <http://www.snetp.eu/>
- [9]: EU/Euratom project ADRIANA project roadmap, 2010, https://cordis.europa.eu/docs/projects/files/249/249687/adriana-final-report_en.pdf
- [10]: European energy Research Alliance Joint Programme on Nuclear Materials EERA-JPNM <http://www.eera-jpnm.eu/>

- [11]: EERA-JPNM SRiA Strategic Research Agenda, Materials for sustainable Energy, <http://www.eerajpnm.eu/filesarer/documents/Materials%20for%20Sustainable%20NuclearEnergy%20%20SRA%20of%20the%20EERA-JPNM%20-%20web%20version.pdf>
- [12]: EERA-JPNM SRiA Strategic Research Agenda, Materials for sustainable Energy ANNEX, http://www.eera-jpnm.eu/filesarer/documents/Annex_to_EERA-JPNM_SRA.pdf
- [13]: S. Sen et al., "A versatile coupled test reactor concept", Proc. of FR17, International Conference on Fast Reactors and Related Fuel Cycles, 26 – 29 June 2017, Yekaterinburg, (Russian Federation).
- [14]: A.L. Izhutov, "Potential Capabilities of Operating Reactor BOR-60 and Reactor MBIR under Construction to Perform Experiments on Transmutation of Minor Actinides", Proc. of FR17, International Conference on Fast Reactors and Related Fuel Cycles, 26 – 29 June 2017, Yekaterinburg, (Russian Federation).
- [15]: K. Pasamehmetoglu, "Versatile Test Reactor Overview", Advanced Reactors Summit VI, San Diego, CALIFORNIA, January 29-31, 2019.
- [16]: IAEA Integrated Nuclear Fuel Cycle Information Systems (INFCIS, <https://infcis.iaea.org/>) web site is a resource for technical and statistical information about nuclear fuel cycle activities worldwide, as reported to the IAEA's Nuclear Fuel Cycle and Materials Section in the Division of Nuclear Fuel Cycle and Waste Technology.
- [17]: Nuclear Data Bank of NEA/OECD, <http://www.oecd-nea.org/dbdata/>
- [18]: IAEA Nuclear Data section <https://www.nds.iaea.org/>, Compendium of Neutron Beam Facilities for High Precision Nuclear Data Measurements <https://www.nds.iaea.org/publications/tecdocs/iaea-tecdoc-1743/>
- [19]: G. Gaillard-Groleas et al., "Improvements in simulation tools to be developed within the framework of the ASTRID project", Proc. of ICAPP 2016, San Francisco, CA, April 17-20, 2016.
- [20]: G. Gaillard-Groleas et al., "The qualification processes of simulation tools, components and systems with the framework of the ASTRID Project – Description and examples", Proc. of ICAPP 2017, Fukui and Kyoto (Japan), April 24-28, 2017.
- [21]: NURESIM and NURESAFE, ADVANCED NUMERICAL SIMULATION FOR REACTOR SAFETY, pp.171- 192, FISA2013 8th Euratom Conference Proceedings, Javier Jiménez, Bruno Chanaron, Victor Sanchez and Xu Cheng, <https://op.europa.eu/en/publication-detail/publication/e8a84303-9e06-4838-9dc2-54a3f9af17d7/language-en/format-PDF/source-126704318>
- [22]: SALOME platform for numerical simulation <https://www.salome-platform.org/> and URANIE open-source software <https://sourceforge.net/projects/uranie/>
- [23]: Idaho National Laboratory's MOOSE (Multiphysics Object Oriented Simulation Environment) <https://moose.inl.gov/SitePages/Home.aspx>
- [24]: C. Fiorina et al., "An Initiative for the Development and Application of Open-Source Multi-Physics Simulation in Support of R&D and E&T in Nuclear Science and Technology", PHYSOR2020.
- [25]: M. Blanc et al., "Codes and Standards strategy for the ASTRID Project", Proc. Of ICAPP 2016, San Francisco, CA, April 17-20, 2016.
- [26]: J. Shi et al., "A Comparison of Different Design Codes on Fatigue Life Assessment Methods", Proceedings of the ASME 2016 Pressure Vessels and Piping Conference PVP2016 July 17-21, 2016, Vancouver, British Columbia, Canada.
- [27]: INSTN, Institut National des Sciences et Technologies Nucléaires <http://www-instn.cea.fr>, I2EN, the International Institute for Nuclear Energy <http://www.i2en.fr>
- [28]: SCK•CEN Academy for Nuclear Science and Technology, http://www.sckcen.be/en/Education_training/SCKCEN_academy
- [29]: ENEN European Nuclear Education Network Association <http://www.enen.eu/>
- [30]: IAEA CLP4NET Cyber Learning Platform for Network Education and Training <http://clp4netkm.iaea.org/index.html>
- [31]: IAEA booklet on the status of SMR technology developments published in 2018. https://aris.iaea.org/Publications/SMR-Book_2018.pdf. This booklet is intended as a supplement to the IAEA Advanced Reactor Information System (ARIS), which can be accessed at <http://aris.iaea.org>

X. MECHANISMS AND APPROACHES FOR COLLABORATIVE R&D ACTIVITIES

The GIF specific initiatives

Forward looking and planned activities of GIF RDTF in view of meeting its second objective will be discussed, the latest being to 'Promote the utilization of the experimental facilities for collaborative R&D activities among the GIF partners' or beyond. Collaboration and synergies between GIF Member States and together with other international organizations is needed to promote R&D on Gen-IV systems efficiently and effectively. It will also help to achieve GIF's four goals namely Sustainability, Economics, Safety & Reliability, and Proliferation Resistance and Physical Protection.

GIF organization is already an efficient mean to let the experts meet together. Indeed through the Project Management Board regular meetings, technical experts, specialists and operators are gathered, organisation facilities and infrastructures are shown, and first contacts are established. Thus within the 14 GIF Countries, the communication is eased and it is a good starting point to investigate how to go further by involving all GIF members, or by switching to a bilateral program. GIF is meaning Generation-IV International Forum, and in that sense it is really providing a forum to the country' experts to identify the key potentiality to collaborative R&D activities. This Bottom-up approach has been often used within the GIF member countries. It is (and has already been) usually materialized by a joint proposition to an international project call, or by the realization of a bilateral technical agreement and joint experiments. Some real case of these mechanisms are presented in Appendix 1 and 2.

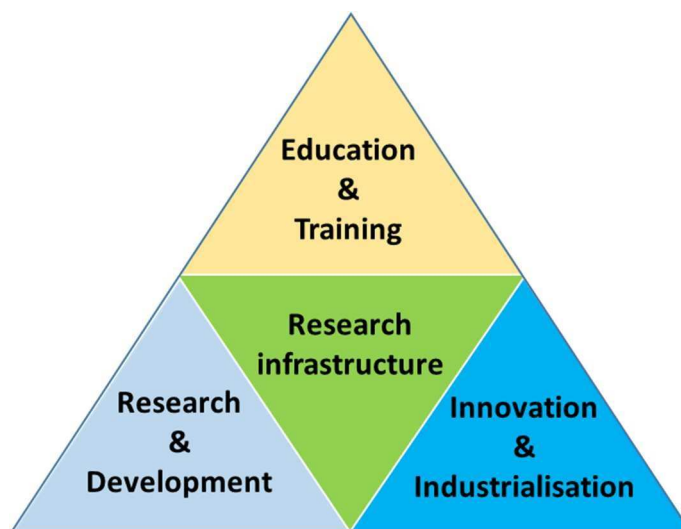

Figure X-1: Research infrastructures positioned within the 'Knowledge Triangle' adapted from [1]

The ICERR initiative (<https://www.iaea.org/about/partnerships/international-centres-based-on-research-reactors-icerrs>) driven by IAEA is a concrete illustration of the research infrastructures positioned within the Knowledge Triangle. Indeed, the IAEA designated International Centre based on Research Reactors (ICERRs) scheme is intended to help IAEA Member States gain timely access to relevant nuclear infrastructure based on research reactors (RRs) to achieve their capacity building and R&D objectives. ICERRs are organizations which make their RRs, ancillary facilities, and resources available to organizations and institutions of IAEA Member States through bilateral arrangements, facilitated by the IAEA. The ICERR scheme enhances the utilization of existing RR and associated facilities, effectively contributing to the development and deployment of innovative nuclear

X. MECHANISMS AND APPROACHES FOR COLLABORATIVE R&D ACTIVITIES

technologies: the Belgian Nuclear Research Centre (SCK•CEN), the French Alternative Energies and Atomic Energy Commission (CEA) – Research Centres of Saclay and Cadarache, the Korea Atomic Energy Research Institute (KAERI), the Russian Research Institute of Atomic Reactors State Scientific Centre (RIAR), the United State Department of Energy - US DOE Idaho National Laboratory (INL), and the United State Department of Energy - US DOE Oak Ridge National Laboratory (ORNL).

For sure in the future, the numbers of collaborations can be enhanced and an optimal use of GIF Member States' infrastructures should be vigorously pursued. It is essential to minimise large investment and/or upgrade capital costs, to further improve any cooperation between research facilities, to facilitate trans-national access wherever possible, and to maintain skills in all fields of nuclear sciences. To this end, GIF future actions are to identify the main existing legal and financial mechanisms, and organizational approaches, to foster any further collaborative access to relevant GIF Member States' R&D facilities identified by this task force.

Its future action will be too to enlarge the accessibility of the GIF experimental fleet to other research institution and private companies by proposing:

- a better knowledge to the GIF facility fleet and all their potentialities,
- an easy access of key contact person to engage the first technical discussions (feasibility phase),
- a clear explanation on the various technical and financial mechanisms to perform the use of a facility from a foreign country and/or another research organization. In addition the GIF organization shall explain the pros and cons of the several mechanisms proposed (everything based on real case feedback).

In addition, GIF Senior Industry Advisory Panel (SIAP) guidance and engagement could further benefit from R&D cooperation and future deployment of technologies. The SIAP can play a role in linking the private sectors needs and requirements with the GIF Experimental facility fleet.

It should benefit from closer OECD Nuclear Energy Agency (NEA), GIF and the International Atomic Energy Agency (IAEA) international cooperation initiatives. Further coordination support to partnerships between public/private industries, research and academic organizations; taking care of potential challenging intellectual property rights; stimulating joint funding from Member States and/or enterprises, can only enhance scientific international cooperation.

GIF will also contribute to promote this activity by specific internal initiative (Workshop, Specific Role of a dedicated Vice Chair, specific GIF Webpage...) which are detailed in [Chapter XI – Key recommendations](#).



Figure X-2: View of the key factor for partnership

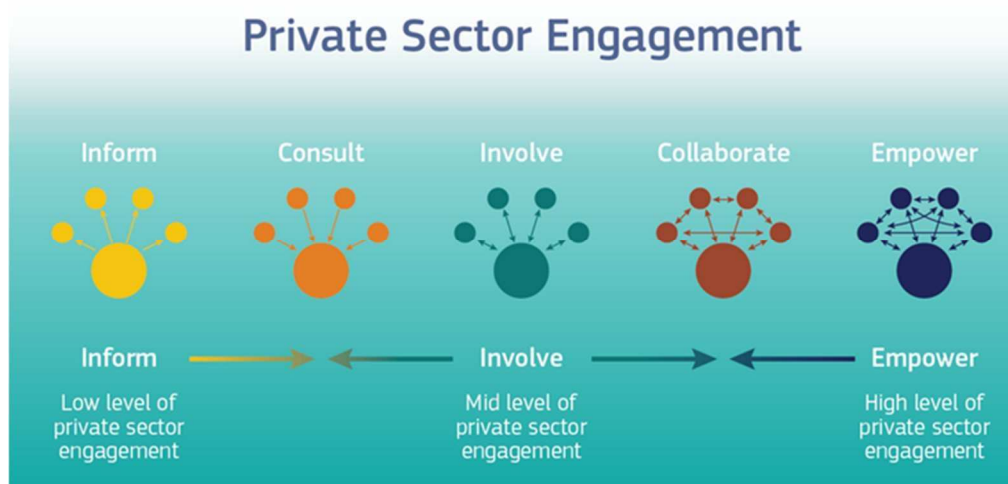

Figure X-3: Conditions for private sector engagement

The GIF interaction with other Scientific Nuclear Organization

GIF has significant collaborations with the IAEA. Annual meetings are organised between GIF and IAEA International Project on Innovative Nuclear Reactors and Fuel Cycles (INPRO), interactions with the Departments of Nuclear Energy, Nuclear Safety and Security, as well as Safeguards and Technical Working Groups within the Department of Nuclear Energy. Evaluation methodologies, specific topical areas - LMFR (SFR and LFR), VHTR, MSR, SCWR, non-electrical applications, education and training, R&D infrastructures, modelling and simulation - are significant possible areas for a broadened and strengthened cooperation between GIF and the IAEA members or countries. Till now, the main focus has been on information exchange, methodology development, development of safety design criteria, and establishing guidelines e.g. guidance for PR&PP, SFR SDC/SDG, licensing framework for advanced reactors, and implementation of SDC/SDG by designers of innovative SFR concepts. These are good achievements but we can go further.

GIF RDTF should benefit from IAEA's key initiative on International Centres based on Research Reactors (ICERR) which is intended to help Member States gain timely access to relevant infrastructure based on Research Reactors facilities, to achieve the nuclear R&D and capacity building objectives relevant to their identified national priorities. ICERRs are organizations which make their Research Reactors, ancillary facilities, and resources available to organizations and institutions of IAEA Member States through bilateral arrangements, facilitated by the IAEA. Excellence is gathered today around the French Alternative Energies and Atomic Energy Commission (CEA, Research Centers of Saclay and Cadarache), the Russian Research Institute of Atomic Reactors State Scientific Centre (RIAR), the Belgian Nuclear Research Centre (SCK•CEN), United State Department of Energy (US DOE) Idaho National Laboratory (INL) and Oak Ridge National Laboratory (ORNL).

The Task Force will benefit from (and will provide any) relevant updates of IAEA databases such as: a) Facilities in Support of Liquid Metal-cooled Fast Neutron Systems Facilities and its latest compendium (LMFNS); b) The Advanced Reactor Information System (ARIS); c) The Research Reactor database (RRDB); and IAEA Cyber Learning Platform for Network Education and Training (CLP4NET), an online platform that allows users to find educational resources easily.

X. MECHANISMS AND APPROACHES FOR COLLABORATIVE R&D ACTIVITIES

OECD Nuclear Energy Agency (NEA) addresses scientific and safety issues for both current and advanced concepts of nuclear energy systems and helps to maintain the necessary R&D infrastructure through international co-operation. A winning strategy for both GIF and NEA organizations is a more systematic involvement of GIF SSCs and PMBs representatives in relevant NEA activities and future programmes together with NEA's participation at GIF PG meetings to present a broader view of its activities relevant and complementary to GIF actions.

OECD/NEA Research and test facilities database (RTFDB), OECD/NEA Task Group on Advanced Experimental Facilities (TAREF) on SFR and GFR but also the Support Facilities for Existing and Advanced Reactors (SFEAR) will benefit the assessment of this task force.

OECD/NEA Nuclear Innovation 2050 Roadmap Initiative (NI2050) has been launched in July 2015. Its objectives are fully complementary to the ones of GIF RDTF and synergies should emerge in due time: a) to map existing nuclear fission R&D programmes and infrastructures; b) to define R&D priorities enabling innovation and to foster the longer term role of nuclear fission in a sustainable low carbon energy future; and c) to evaluate the potential for international cooperation (EU, JP, KR, CA, RU, US, further NEA participant countries) which could enable the implementation of some of these priorities, in particular when gaps have been identified.

Similarly, one has to assess how the GIF RDTF could benefit from the Department of Energy Office of Nuclear Energy (DOE-NE) latest initiative. It has established the Gateway for Accelerated Innovation in Nuclear (GAIN) to provide to the national (US) nuclear community with access to the technical, regulatory, and financial support necessary to move innovative nuclear energy technologies toward commercialization while ensuring the continued safe, reliable, and economic operation of the existing nuclear fleet.

OECD/NEA Nuclear Education Skills and Technology's (NEST) Framework launched in May 2017 should help address important gaps in nuclear skills capacity building, knowledge transfer and technical innovation in an international context. It is a multinational approach inherently attractive to young people and of large interest for GIF RDTF.

GIF Member States, OECD/NEA or IAEA, all have a long-standing experience in co-founding collaborative research programmes with the participation of public/private consortia, following competitive call for proposals or on an ad-hoc basis. GIF Members States provide to support researchers, by integrating activities combined in a closely coordinated manner: a) Networking activities, to foster a culture of co-operation between research infrastructures, scientific communities, industries and other stakeholders as appropriate, and to help develop a more efficient and attractive framework; b) Transnational access or virtual access activities, to support scientific communities in their access to identified key research infrastructures; and c) Joint research activities, to improve, in quality and/or quantity, the integrated services provided international level by these infrastructures.

Because of its position within all Member States' relevant bodies, and close relationship with key influential nuclear institutions, GIF should play a pro-active role in ensuring any optimization of available experimental platforms, and sustainable use on a longer-term. It will be done effectively by:

- promoting regular meetings to update relevant catalogues, compendium or databases of installations (at least once every two years);
- recalling this subject is essential when preparing future international symposia and seminars;
- being the driving and a force for proposals within the frame of international initiatives, which could promote the experimental infrastructures, or enable the creation of new shared tools.

X. MECHANISMS AND APPROACHES FOR COLLABORATIVE R&D ACTIVITIES

In today's highly competitive market, organizations gain competitive advantage by collaborating on innovations. However, in general, before a successful partnership can start, organizations will have to negotiate ownership and access to the intellectual property produced as a result of the joint effort. While some collaborative projects are not created to pursue commercial gains, outputs of collaboration may have commercial application. Experience shows that the framework for the collaboration should be determined through an agreement that describes the project and the future ownership, management and exploitation of the Intellectual Property. The attractiveness of a collaborative project is increased if such framework can be negotiated timely. It is important that the partners agree on the allocation of ownership, transfer, and access to Intellectual Property before the project starts. This is done to reduce uncertainties and to protect the rights of the partners. Partners should agree not only on the owners of the future intellectual property but also on the ways for subsequent commercial exploitation of the results of the collaboration. A timely negotiated and successfully finalized framework for IP ownership and management plays a key role in protecting partner investments and ensuring the successful exploitation of the results of the collaboration. The IP rights must not be the main bottleneck of a fruitful and timely cooperation. Therefore, anticipation of the key solution.

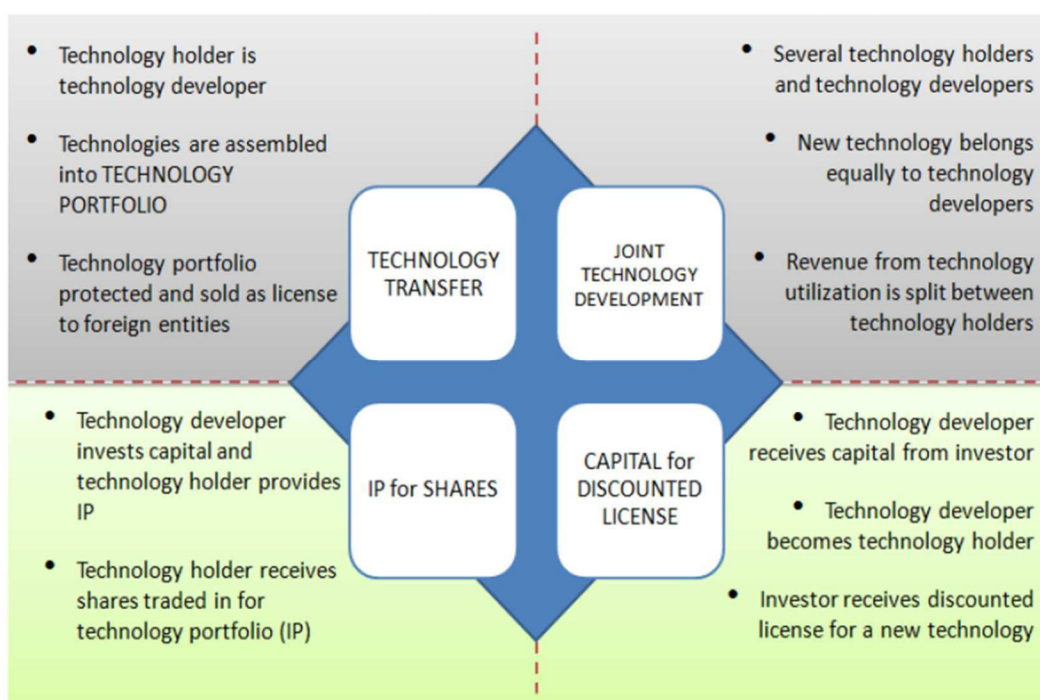

Figure X-4: Collaborative projects, Intellectual Property Rights and Knowledge Assets management options

With the benefit from almost 20 years of successful international cooperation, GIF should bring further opportunities to collaborative research, innovation and demonstration projects. The Generation-IV International Forum (GIF) framework on 'International development of advanced nuclear energy systems' is the Framework Agreement for International Collaboration on Research and Development of Generation-IV Nuclear Energy Systems. Member States organizations and implementing agents of the GIF framework agreement have signed system arrangements supporting collaborative projects, where Intellectual Property Rights and Knowledge Assets management options are managed adequately. Participation of public/private consortia e.g. SMR vendors, should be seen as an opportunity towards higher scientific, innovation and economic impact.

The GIF RDTF initiative to promote new mutualized facilities and Education & Training tools.

As the refurbishment and/or construction of the next generation of large-scale facilities is increasingly complex and costly, innovative ‘financial and legal frameworks and/or mechanisms’ are needed and the GIF RDTF will further assess the most promising ones. Recommendations by Member State’s ministry representatives, research programme owners and programme managers, research and technical organisations, industrial representatives and relevant international for a included support through: a) loans for research infrastructures; b) tax exemptions e.g. thanks to a dedicated Joint Undertaking legal entity; c) incentives (or grants) dedicated to the construction of research infrastructures; d) attracting private investors, energy providers or research organisations; e) capitalising any access to national public research organisations; f) sharing investments from the hosting country to support infrastructures as a host of any new facility.

Another successful contribution should be from EU/Euratom Education and Training (E&T) initiatives which are increasingly being organized with the support of the EU/Euratom to the European Nuclear Education Network (ENEN), and within the frame of projects co-funded through the Euratom Framework Programmes. ENEN was established in 2003 as a French non-profit association to preserve and further develop expertise in the nuclear fields through Higher Education and Training. ENEN has currently over 60 members, mainly in Europe but also from Japan, Russia, South Africa, Canada, Ukraine including strengthen cooperation with IAEA. This objective is realized through the cooperation between universities, research organizations, regulatory bodies, industry and any other organizations involved in the application of nuclear science, and supporting international mobility of young scientists or researchers, mutual recognition of competences, giving overall a new impetus, high incentives and perspectives for E&T within Europe and Internationally. In this area, GIF also has to promote any optimal use of Member States’ existing infrastructures – or, if necessary, think about jointly building new ones – and, partially or completely:

- Dedicate these to education and training activities for a larger audience,
- Ensure any knowledge management, transfer of good operating practices, and to make operating knowledge available on specific heat coolant fluids, different from water and often operating at high, even very high temperatures, and
- Focus on dissemination of a safety and security culture in relation to the specific use of these coolants e.g. with the support of publishing books, guidelines, good practices and recommendations for the safe use and operation of experimental facilities operating non-aqueous coolants.

X. MECHANISMS AND APPROACHES FOR COLLABORATIVE R&D ACTIVITIES

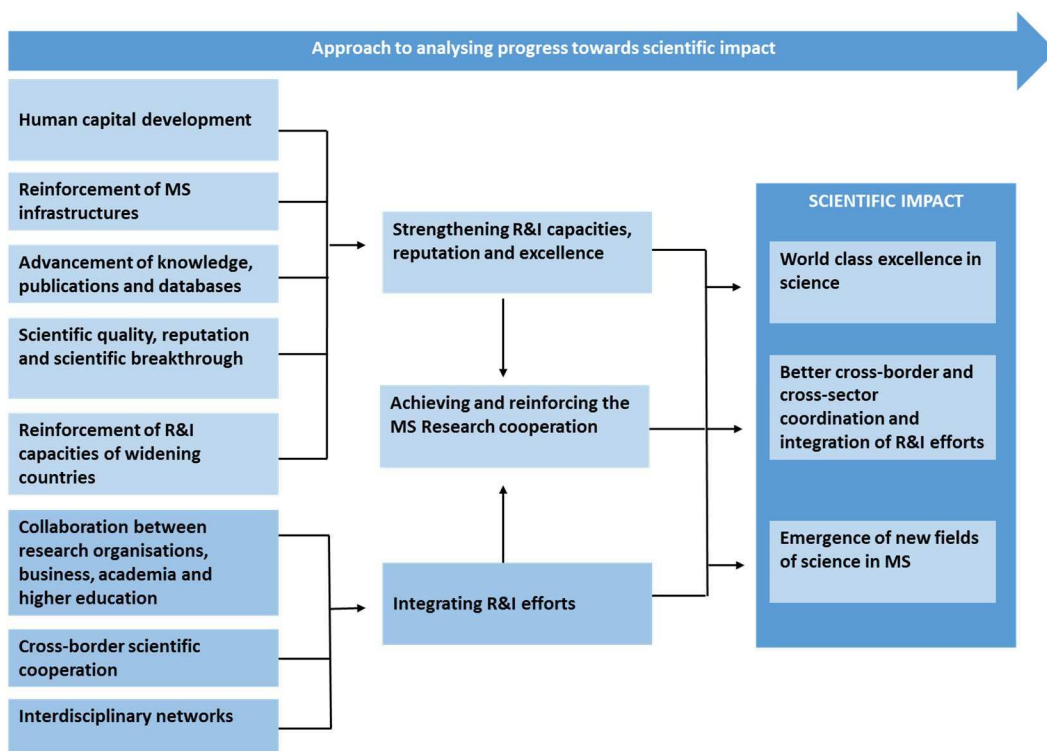

Figure X-5: Progress towards Scientific Impacts

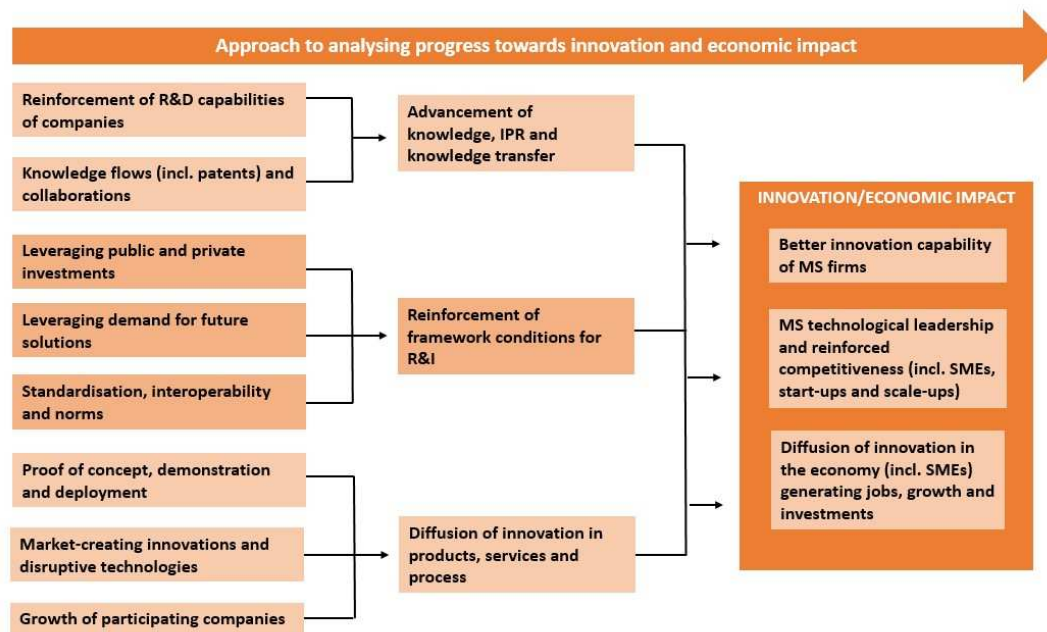

Figure X-6: Progress towards Innovation and Economic Impact

REFERENCE

[1]: European Commission, 'A vision for strengthening world class research infrastructure in the ERA', ISBN, ISBN 978-92-79-14214-7, 2010.

XI. KEY RECOMMENDATIONS

As previously expressed within this report, one of the objectives of the GIF RDTF Task Force was to use this opportunity to support any update of existing open databases rather than to duplicate an exhaustive catalogue of experimental facilities available for the six systems and cross-cutting activities. These actions are - and remain – the responsibility of nuclear organizations such as IAEA and OECD/NEA. It was not considered useful (or necessary) at this stage of analysis, to duplicate such an approach within GIF. The Task Force initiative was more orientated towards a thorough assessment of GIF Member States experimental infrastructures, state of play and current snapshot, to provide an update of existing databases e.g. IAEA LMFNS, GFR-(V)HTR, and to identify the most effective actions that GIF could/should undertake:

- To have a better overview of its Member States' assets and more specifically to identify any gaps in the current available experimental facilities. This also allows to have a better vision of future prospects in the framework of GIF (or trends over 5-10 years),
- To favor a coherent and efficient management of experimental infrastructures needed to the different GIF systems, with a vision to broaden transnational level exchanges,
- To promote and intensify initiatives for cooperation and exchange, and / or joint development of experimental programs on dedicated facilities, made available or shared,
- To clarify, simplify and promote any framework or mechanisms, legal or funding instruments allowing the use and exploitation of experimental infrastructures by third countries, other organizations, or by the private sector.

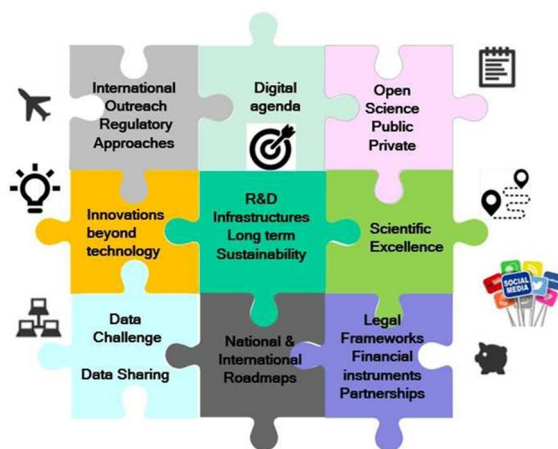

Figure XI-1: The key puzzle piece for success

To complete the joint work produced by this Task Force, a dedicated Workshop organized over two days, on February 19-20 2020, facilitated to understand and collect the needs of SMR Vendors and the Private Sector (see on the GIF Website). As a result, members of the RDTF have issued a list of recommendations, to define lines of action and developments, subject to the assessment of GIF Expert Group members and for final approval of the GIF Policy Group members. Taking into account all - or part - of these recommendations at the level of GIF Management Board should make it possible to consider experimental infrastructures as key to guarantee the necessary support for the development of Gen-IV systems. The aim is to ensure that the availability and optimized use of the international experimental infrastructures permit the proper development of all GIF Member States' R&D actions

needed for the progress of the six Gen-IV systems and cross-cutting fields. These infrastructures should also have the objective to best meet any requirements emanating from the private sector.

Outcome of the GIF R&D Infrastructure Task Force:

The Task Force considers that, in future, GIF should operate according to the following two main lines of actions:

1. GIF considered as an ACTOR AND HOST

This action is to be considered at a high strategic level within GIF since it is placed as one of the three main missions addressed to GIF Vice-Chairs:

- GIF shall provide a dedicated webpage on R&D Infrastructure which will be an open door where all members and non-members could get enter to start the connexion with the R&D Infrastructure net.
- GIF shall provide key contact person list to know exactly who to join and to contact.
- GIF will investigate how to provide a way to get access to facilities with an easier and smarter access to databases rather than a simple compendium.
- GIF shall publicize and disseminate the information produced on this subject by the Member States organizations, bodies in charge e.g. OECD/NEA and IAEA, and international specialists.
- GIF shall keep alive the network with SMR Vendors and private actors, mainly through its specific GIF database and through various communication tools it is starting to implement
- GIF shall evaluate the progress and achievements in that field dedicated by organizing dedicated workshops. The first one (February 2020) has been considered to be a success. It should be renewed, together with SMR Vendors, as stated by the GIF Chair (H. Kamide) during the GIF workshop conclusions (see Annex n°3).

2. GIF considered as an INFLUENTIAL NON-PROFIT ORGANISATION

It is a GIF role to:

- Systematically remind authorities in charge of carrying out this essential – but sometimes tedious - work of regularly updating databases of available infrastructures. They are greatly thank to organize this work and GIF will actively contribute to any initiative.
- Alert or notify these organizations regarding any points for improvement or update (and in case propose solutions and quick remediation actions).
- Assure the voice of GIF – comprising 14 Member States countries - is heard so that this theme on R&D infrastructures is considered in the preparation of future large organizations of symposia, or specialists meeting, or call for proposals.

Future of the GIF R&D infrastructure Task Force:

The Missions assigned to this Task Force have been successfully fulfilled. It is not considered relevant to pursue the actions of this Task Force, as such, with the same missions stipulated in the RDTF Terms of Reference. In accordance with the key recommendations given above, and with regards to the position of the GIF Policy Group upon them, it will be necessary to determine how will be articulated and should evolve these initiatives.

Taking into account analyses and recommendations made by RDTF members, as well as private sector's feedback from the first Workshop in February 2020, it would be preferable to see a new dedicated Task Forces emerging from the conclusions of this RDTF report.

Moreover, following all the recommendations set out above, it is necessary to highlight two topics largely put forward during the RDTF workshop. They are the sharing of:

- The Verification/Validation and Uncertainty Quantification (VV&UQ) approaches and best practices between the different Member States,
- The reflection on how to improve exchanges with regulators, at an early stage, to simplify and enable faster licensing processes for any innovative systems e.g. SMRs.

These two items could be the starting point of new GIF Task Forces that would be considered in such a way as a logic continuation of this RDTF Task Force.

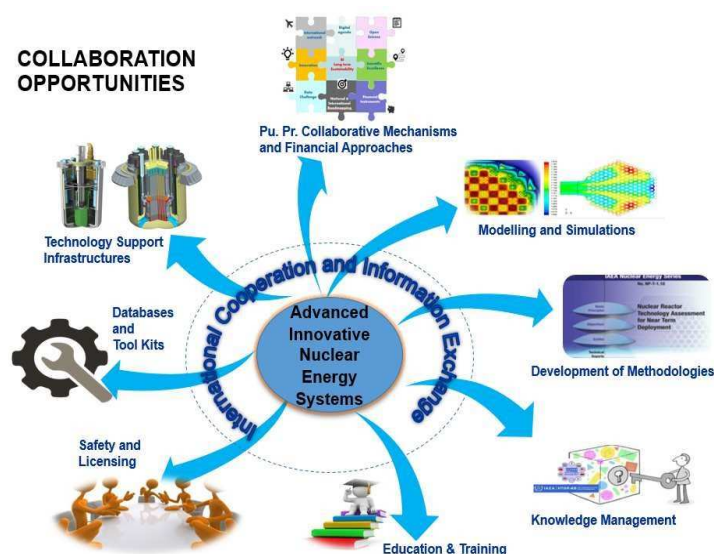

Figure XI-2: The virtuous wheel of International cooperation

XII. CONCLUSIONS

Today's Research Infrastructures include major scientific equipment, scientific collections, structured information, ICT-based infrastructures. They are single sited or distributed throughout several countries. GIF Member States are faced with a wide spectrum of issues, from infrastructures, which are globally, unique to many regionally distributed. Many stakeholders are involved, from ministries to researchers and industry, with an underlying and growing use of e-infrastructures. There are opportunities but also difficulties:

- of interaction between basic research and industry,
- public and private funding is always lacking,
- and single countries very frequently do not have the critical mass or the dimension to implement large research infrastructures.

Moreover these large infrastructures remains very costly to operate and their low load factor remains a significant concern. Therefore, there is a real need to cooperate on a wide International level. Substantial RD&D systems' conceptual/detailed design and analysis are needed. Refurbishment and/or construction or even under cocooning of research infrastructures and facilities are increasingly complex and costly. Therefore there is a real need to cooperate on a wide International level.

An opportunity exists, by identifying the latest R&D needs and mapping of infrastructures, to plan for the shared use of existing ones, and to undertake the development of new ones. Most important are within the areas of fuel cycle, fuels and materials irradiation, reactor safety, dedicated loops, mockups and test facilities, advanced simulation and validation tools, transnational access to infrastructures, and education, training and knowledge management of scientists and engineers.

All contributions are the result of a common effort of all partners involved and it is very appreciated by the entire scientific community. GIF Member States can strongly support a coordinated revitalization of nuclear Research, Development & Demonstration & Innovative infrastructures worldwide to a level that would once again move a new generation forward quickly.

In this report, the GIF R&D Infrastructure Task Force has proposed several key recommendations and orientations to ease and foster the highest impact from collaborating opportunities within the GIF framework. These actions proposal are now being examined at the GIF Governance level for future implementation in key areas identified within the virtuous wheel of International cooperation.

XIII. APPENDIX

APPENDIX n°1: An example of the collaborative framework starting from the Generation-IV International Forum: the Japanese/French collaborative R&D on SFR

Collaborations between public/private industries and research organizations of two countries with a common objective of development of Generation-IV systems allow sharing the cost of the development, the national facilities to support the development, and the R&D results. An example is the Japanese-French collaboration on the ASTRID program and Sodium Fast Reactor. A General Arrangement between CEA, and Japanese Ministries MEXT and METI, was signed in May 2014 until the end of 2019. An Implementing Arrangement was signed in August 2014, between CEA, AREVA NP (now Framatome), JAEA, MHI and MFBR (Fig. 1). This collaboration, described in 39 Task Sheets, covers ASTRID joint design (active Decay Heat Removal System, Curie Point Electro Magnet for diversified control rods, Seismic isolation system, Above Core Structure, Polar Table, Core Catcher, and cross evaluations), and R&D supporting work for different topics (28 R&D Task Sheets): Severe Accident, Fuel and Core materials, Reactor materials, Reactor technology, and Thermohydraulics [1].



Figure 1: Signature of the France-Japan General Arrangement on the ASTRID programme and Sodium Fast Reactors in 2014 with Japanese Prime Minister S. Abe and French President F. Hollande

The cooperation is balanced between the two countries, and there are no money exchanges as a general rule. In specific subjects that implies new experimentations, a financial contract could be defined. The R&D supporting program are jointly defined, and experiments with associated analyses are carried-out in facilities of both countries [2]. For expensive tests such as in-pile experiments, the first step was to jointly study the feasibility of the tests. Main achievement requiring experimental facilities for Severe Accident was the study of steel jet interaction with Sodium in the MELT facility located in Japan (Fig.2). Behaviour of material mixtures at high temperature have been jointly studied in facilities of both countries.

Also information on experimental programs carried-out in the In-Pile facility IGR operated by NNC-RK in Kazakhstan was shared [3]. For Fuel studies, feasibilities of fuel elements irradiation in JOYO was studied; for Reactor Material developments, the Electron Beam welding technique of dissimilar materials was improved with microstructure characterizations and mechanical property measurements in Japan and France. ODS cladding irradiation properties were also compared. Regarding instrumentation developments, tests at high temperature in JOYO of Neutron Flux Monitoring sensor have been prepared. For Reactor component R&D, ASTRID prototypic component testing in ATHENA facility was jointly discussed. At last experimental programmes on Reactor Thermohydraulics (decay heat removal from fuel assemblies) studies in PLANDTL 1&2 facilities were discussed. This led to a Collaborative Work Program carried out in PLANDTL-2 facility (Fig. 3, [4&5]) with CEA co-funding.

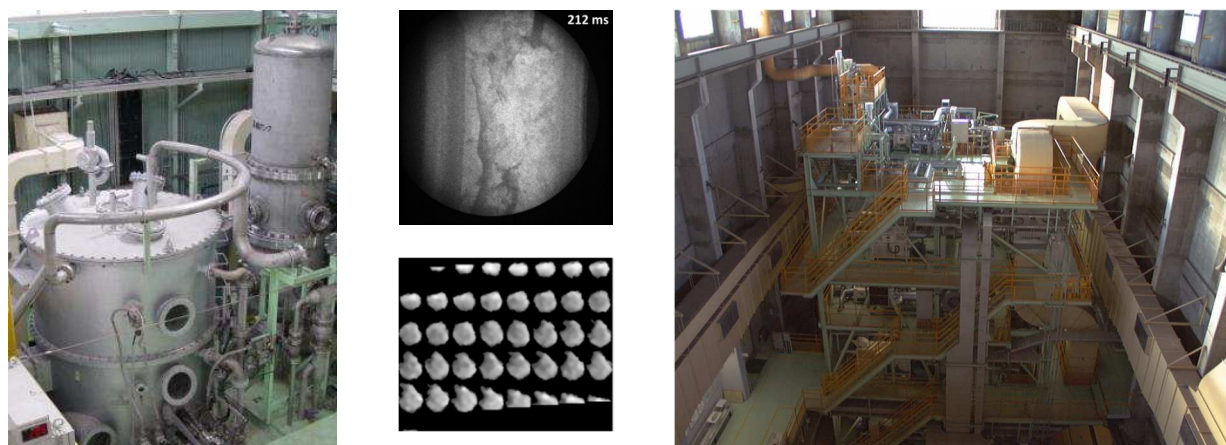
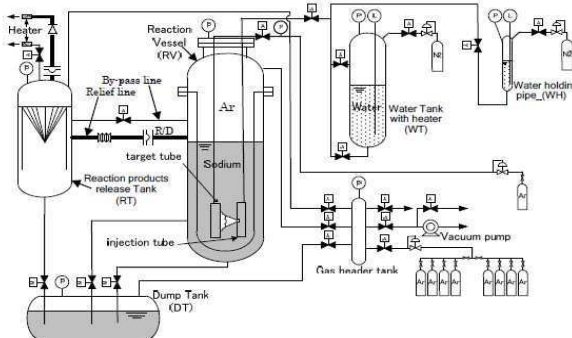

Figure2: Left: MELT facility, steel jet injection in Sodium, fragment tracking by X-ray imaging; Right: PLANDTL-2 facility and steel

The tight collaboration between Japan and France between 2014 and 2019, sharing experimental facilities and results, was very fruitful. Therefore it was decided to continue this type of bilateral cooperation and a new General Arrangement for Fast Reactor Development Program collaboration between CEA, MEXT and METI was signed on June 26, 2019, and an Implementing Arrangement between CEA, Framatome, JAEA, MHI and MFBR was signed on December 3, 2019 (32 Task Sheets). R&D activities in Japanese and French facilities started in 2014 will continue until the end of 2024. It must be pointed out that a new Task Sheet has been set-up in the new Implementing Arrangement to exchange information on experimental platforms (Sodium test loop, irradiation facilities, and mechanical test facilities) for possible future collaboration programs in these facilities.

- [1] F. Varaine, G. Rodriguez, J.M. Hamy, S. Kubo, T. Iitsuka, et al.. *The significant collaboration of Japan and France on the design of ASTRID sodium fast reactor since 2014. GIF Symposium Paris (France) 16-17 October 2018, Oct 2018, Paris, France. (cea-02328977)*
- [2] Devictor, Nicolas & Chikazawa, Yoshitaka & Saez, Manuel & Rodriguez, Gilles & Hayafune, Hiroki. (2013). *R&D in Support of ASTRID and JSFR: Cross-Analysis and Identification of Possible Areas of Cooperation. Nuclear Technology. 182. 170-186. 10.13182/NT13-A16429.*
- [3] F. Serre, F. Payot, C. Suteau, L.Trotignon, E. Batyrbekov, A. Vurim, A. Pakhnits, V. Vityuk, S. Kubo, A. Katoh, Y. Tobita, K. Kamiyama, K. Matsuba, J. Toyooka, (2016). *R&D and Experimental Programs to support the ASTRID Core Assessment in Severe Accidents Conditions, Proceedings of 2016 international congress on advances in nuclear power plants (ICAPP2016), USA*
- [4] A. Ono, M. Tanaka, Y. Miyake, E. Hamase, T. Ezure, (2019). *Preliminary Analysis of Sodium Experimental Apparatus PLANDTL-2 to Develop Evaluation Method for Thermal Hydraulics in Reactor Vessel of Sodium-cooled Fast Reactor under Decay Heat Removal System Operation Conditions, Proceedings of the 27th International Conference on Nuclear Engineering (ICONE27), Japan*
- [5] T. Ezure, T. Onojima, M. Tanaka, J. Kobayashi, A. Kurihara, Y. Kameyama, (2019). *Study on multidimensional core cooling behavior of sodium-cooled fast reactors under DRACS operating conditions, Proceedings of 18th International Topical Meeting on Nuclear Reactor Thermal Hydraulics (NURETH-18), USA*

APPENDIX n°2: An example of a R&D Joint Collaboration R&D on SFR (Contractual approach)

Gen-IV R&D Joint collaboration	
Context	Joint collaboration between France (CEA) and Japan (JAEA) to use the Japanese facility (SWAT-1R) to realize Sodium Water Tests on Ferritic materials
Period	- Very first contact : June 2009 - Completion of the work : tests = March 2012 ² - Final report Dec. 2012 - Common publication March 2013.
Facility name :	SWAT-1R (O' Arai – Japan) 
Concerned field(s) :	Sodium Water Reaction Testing
Contact person :	See JAEA (during the tests, the 1 st contact person was H. Hayafune)

1. **Is this facility in operation** Yes No

If no, What is the state of the facility? SWAT-1R facility is dismantled and kept due to building seismic resistance. SWAT-3R (larger facility) can make some equivalent experiments.

2. **Is this facility open to GIF collaborative work?**

Yes No But assembly and adjustment will be needed.

3. **Does any collaborative mechanisms already exist?** Yes No

If Yes, which one? Bilateral (CEA/JAEA after first connection through GIF SFR CD&BOP Project Management Board)

GIF

AIEA

OECD/NEA

Other

4. **What are the potential collaborative mechanisms?**

Joint collaborative work financed by France. French part is providing the specifications and JAEA leading as the facility expert and operating the experiment (with the presence of the French part) and providing the results and interpretation.

² The tests were first scheduled in April 2011 but due to the Fukushima event, we faced almost one-year delay.

5. **Is any support helpful in this approach (from GIF, IAEA, OECD ...)? Moreover, what could be the support?**

No support are required. Once this bilateral work has been done, we can gain of this experimental feedback to simplify the process for the next time

6. **Is there any material support that could highlight this joint work?**

A joint publication produced during the IAEA FR2013 meeting conference.

Cooperation on impingement wastage experiment of Mod. 9Cr-1Mo steel using SWAT-1R sodium-water reaction test facility

F. Beauchamp^{a1}, M. Nishimura^{b2}, R. Umeda^b, A. Allou^a

^a CEA (French Alternative Energies and Atomic Energy commission),
Nuclear Energy Directorate,
Cadarache center, France

^b JAEA (Japan Atomic Energy Agency),
Oarai R&D center,
Narira, Oarai, Ibaraki,
Japan

Abstract. The loss of tightness from a Steam Generator Unit (SGU) tube results in high-pressure steam or water leak into sodium causing a Sodium-Water Reaction (SWR), highly exothermic, with corrosive products leading to a local erosion-corrosion called "wastage" of neighbouring tubes. Under the collaboration between CEA and JAEA, wastage experiments were carried out on Mod. 9Cr-1Mo steel (T91) tubes. T91 is one of the material candidates of SGU tubes for future sodium-cooled fast reactors (SFRs). Wastage characterization of T91 is needed to evaluate the consequences for safety and the availability of the SGU. Six T91 target tubes were incorporated in the SWR test facility (SWAT-1R) of JAEA and subjected to reaction jets. All tubes were successfully penetrated by the reaction jets, and the wastage rates were determined. The main results are discussed in this paper. These test results contribute to the improvement of wastage rates prediction and to the safety demonstration of future SFRs.

7. **Feedback coming from this experience**

New input data on ferritic material wastage which was necessary to assess the safety demonstration of Steam Generator tube resistance in case of sodium leak.

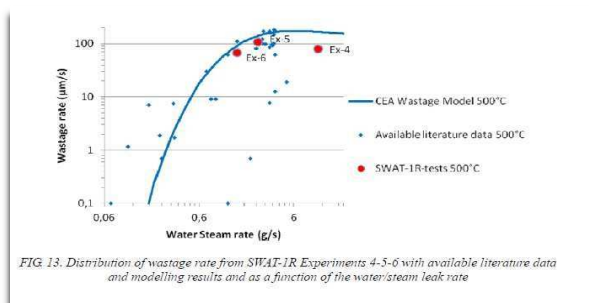

APPENDIX n°3: Concluding Remarks of the GIF Workshop by H. KAMIDE

Thank you very much for very active discussions in these three days. I am very impressed by the discussion here, new information and new idea. It was great fun to have group discussions in the small group. Let me say some concluding remarks based on my understanding. This is not conclusions, but my impressions.

Advanced Manufacturing and Material

Some key technologies were introduced, 1) 3D printing of components which have complicated geometry, 2) powder metal and HIP technique, again for complex component without welding, 3) coating technology to avoid corrosion issue, and so on.

In the summary of the group discussions, several significant points are depicted. Among these, my view is as follows:

1) SMR has some advantage for small components and easy to apply the new technologies. But point is economy and also early deployment of the plants to apply such new technologies. The new technologies have also potential to enable online monitoring during component manufacturing process. It has potential to change the production process of regulation and costs. Classification of Nuclear and Non-nuclear grade components might be changed by such techniques and it brings huge cost reduction.

If so, regulation rules to apply such new technologies to nuclear grade components and manufacturing are required. The code and standards were discussed yesterday. But before the standards, requirement from regulator is needed to establish the standards of ASME, for example. GIF has some channels to discuss with regulatory people, like today or through IAEA, and OECD/NEA. If it is needed, GIF will be able to contribute.

2) One more issue is a kind of platform to gather information or experiences of new technologies on the advanced manufacturing and material. It is tightly connected with IP issues. But more general information of experiences of applications of success and failure for new technologies, schematic ideas of technology, and plans of required infrastructures, such general information might be useful for community of the advanced manufacturing and material. If we can have common component tests for reduction of the cost or for the establishment of the code and standards from the ideas of platform, it will be great.

3) Simulation and qualification are also key issues of the collaborations not only for new technologies but also for new regulation rules, which will need help of simulations to cover the freedom of complex geometry of order-made component manufacturing, not one by one but covering in general.

R&D collaboration and opportunity using infrastructures

We had discussions today with LWR base SMR vendors and regulatory people. Some parts will be common to Gen-IV reactors developments, like advanced manufacturing, modularisation, and digital architectures. There are significant needs of infrastructures for the component tests, demo of passive safety system, and software infrastructure, S.J. Kim san pointed out. In my view, Regulation rules for risk informed approach and smaller EPZ will be also common to Gen-IV reactors. Development of PRA methodologies to define the risk curve of probability and consequence of the reactors will be next priorities for the soft collaboration.

We had more discussions on MSR, LMFR, HTGR and Non-Electric applications. We found several points of collaborations using infrastructures. The component experiments are one of key issues. Platform of the information and experiences, like Czech Republic for MSR, might be useful also in this area.

One more point is irradiation reactors and facilities. International collaboration scheme is needed like HALDEN. Hydrogen production and heat utilisation has large potential as a cross cutting issue to enlarge the advanced reactors of future to go to the Low Carbon Society.

Needs from SMR vendors, just the session before

The GAIN contributes R&D needed for reactor deployment via large knowledge in national labs. from 1960'. Access to the data has legal difficulty of negotiation with university or national labs. Simple process is needed. However, international collaboration has more complexity of the data access. It is one of the points and related to Hittner san's suggestions.

Priority for early deployment is the general standards on QA, ISI, so on. International code and standard are helpful for the cost reduction. To standardize design, not for site to site, will contribute the cost reduction. On the regulator point of view: Code and standards can speed-up the regulation process by reliable path through ASME for example. But the process can be more efficient. Irradiation data can be used for several purposes of rector developments and also regulations under a well-organized collaboration. This is helpful suggestion for us.

As final remarks, let me point out the following things:

- Define the future of the AMME TF with a new TOR to be proposed for the next EG/PG meeting
- Define the future of the RDTF => in short term it is to produce the final report it is ongoing, then to think about the future of this TF. Just an idea is a new TF of methodology on Computing Code Verification Validation and related Qualification including collaborations of experiments using the infrastructure.
- Try to extract from the workshop conclusion for the next SIAP Charge (maybe something like "How to pursue and increase the exchanges with SMR vendors after this workshop") but we need discussion with Eric chair of SIAP.
- Finally, if major of our participants think that this workshop has a success, we can imagine how to vitalize this movement of collaboration, and this kind of Workshop will be a candidate as a regular meeting one time for two to three years.

I appreciate all participants to this workshop and great support by Sama and Sylvia of OECD/NEA.

KAMIDE Hideki
GIF Chair
21/02/2020

APPENDIX n.4: Members' list of the RDTF task force

Roger Garbil ⁽¹⁾, Alfredo Vasile ⁽²⁾, Sang Ji Kim ⁽³⁾, Alexander Stanculescu ⁽⁴⁾, Gilles Rodriguez ⁽²⁾, Said Abousahl ⁽¹⁾, Alessandro Alemberti ⁽⁵⁾, Iurii Ashurko ⁽⁶⁾, Michel Berthelemy ⁽²⁾, Sama Bilbao y Leon ⁽⁷⁾, Stéphane Bourg ⁽²⁾, Andrea Bucalossi ⁽¹⁾, Olivier Gastaldi ⁽²⁾, Frédéric Serre ⁽²⁾, Marc Deffrennes ⁽⁷⁾, Lyndon Edwards ⁽⁸⁾, Mmeli Fipaza ⁽⁹⁾, Petr Fomichenko ⁽¹⁰⁾, Michael Futterer ⁽¹⁾, Jean-Paul Glatz ⁽¹⁾, Gisela Grosh ⁽⁷⁾, Robert Hill ⁽¹¹⁾, Bonnie Hong ⁽⁴⁾, Kamide Hideki ⁽²¹⁾, Victor Ignatiev ⁽¹⁰⁾, Tatiana Ivanova ⁽⁷⁾, Kawasaki Nobuchika ⁽²¹⁾, Vladimir Kriventsev ⁽¹³⁾, Laurence Leung ⁽¹²⁾, Manuel Martin Ramos ⁽¹⁾, Stefano Monti ⁽¹³⁾, Frederik Reitsma ⁽¹³⁾, François Storrer ⁽²⁾, Tomas Sowinski ⁽¹⁴⁾, Henri Paillere ⁽⁷⁾, Pascal Terrasson ⁽²⁾, Kamil Tucek ⁽¹⁾, Antonio Vayasoler ⁽⁷⁾, Lori Walters ⁽¹²⁾, Zukile Zibi ⁽¹⁵⁾, Lei Shi ⁽¹⁶⁾, Donghua Lu ⁽¹⁷⁾, Chengkui Liao ⁽¹⁸⁾, Domenico Paladino ⁽¹⁹⁾, Jonathan Hyde ⁽²⁰⁾, Nishimura Masahiro ⁽²¹⁾, and Daniel Brady ⁽²²⁾

- (1) European Commission, Euratom, Belgium (roger.garbil@ec.europa.eu, jean-paul.glatz@ec.europa.eu, michael.fuetterer@ec.europa.eu, kamil.tucek@ec.europa.eu, manuel.martin-ramos@ec.europa.eu, andrea.bucalossi@ec.europa.eu, said.abousahl@ec.europa.eu)
- (2) Commissariat à l'énergie atomique et aux énergies alternatives, France (alfredo.vasile@cea.fr, olivier.gastaldi@cea.fr, frederic.serre@cea.fr, francois.storrer@cea.fr, gilles.rodriguez@cea.fr, pascal.terrasson@cea.fr, stephane.bourg@cea.fr)
- (3) Korea Atomic Energy Institute, Republic of Korea (sjkim3@kaeri.re.kr)
- (4) Idaho National Laboratory, United States of America (alexander.stanculescu@inl.gov, Bonnie.Hong@inl.gov)
- (5) Ansaldo Nucleare S.p.A, Italy (alessandro.alemberti@ann.ansaldo.it)
- (6) Institute for Physics & Power Engineering, Russian Federation (ashurko@ippe.ru)
- (7) OECD Nuclear Energy Agency, France (michel.berthelemy@oecd-nea.org, henri.paillere@oecd-nea.org, marc.deffrennes@oecd-nea.org, gisela.grosh@oecd-nea.org, antonio.vayasoler@oecd-nea.org, sama.bilbaoyleon@oecd-nea.org)
- (8) Australian Nuclear Science and Technology Organisation, Australia (lyndon.edwards@ansto.gov.au)
- (9) Eskom, South Africa (FipazaM@eskom.co.za)
- (10) National Research Centre Kurchatov Institute, Russian Federation (Ignatev_VV@nrcki.ru, fomichenko_pa@nrcki.ru)
- (11) Argonne National Laboratory United States of America (bobhill@anl.gov)
- (12) Canadian National Laboratories, Canada (laurence.leung@cnl.ca, lori.walters@cnl.ca)
- (13) International Atomic Energy Agency, Austria (Stefano.monti@iaea.org, V.Kriventsev@iaea.org, F.Reitsma@iaea.org)
- (14) Department of Energy, United States of America (thomas.sowinski@nuclear.energy.gov)
- (15) Department of Energy, South Africa (Zukile.Zibi@energy.gov.za)
- (16) Tsinghua University, China (shlinet@tsinghua.edu.cn)
- (17) China Nuclear Power Research Institute, China (ludonghua@cgnpc.com.cn)
- (18) State Power Investment CO Ltd, China (liaochengkui@snptc.com)
- (19) Paul Scherrer Institute, Switzerland (domenico.paladino@psi.ch)
- (20) National Nuclear Laboratory, United Kingdom (jonathan.m.hyde@uknpl.com)
- (21) Japan Atomic Energy Agency, Japan (nishimura.masahiro@jaea.go.jp, kawasaki.nobuchika@jaea.go.jp, kamide.hideki@jaea.go.jp)
- (22) Natural Resources Canada NRCAN-RNCAN (daniel.brady@canada.ca)

APPENDIX n.5: List of abbreviations and acronyms Generation IV International Forum

CD&BOP	Component Design and Balance-of-Plant (SFR signed project)
CD&S	Conceptual Design and Safety (GFR signed project)
CMVB	Computational Methods Validation and Benchmarking (VHTR project)
EG	Experts Group
EMWG	Economic Modeling Working Group
ETTF	Education and Training Task Force
FA	Framework Agreement of GENIV Systems
FCM	Fuel and Core Materials (GFR project)
FFC	Fuel and Fuel Cycle (VHTR signed project)
FQT	Fuel Qualification Test (SCWR project)
GACID	Global Actinide Cycle International Demonstration (SFR signed project)
GIF	Generation IV International Forum
GFR	Gas-cooled fast reactor
HP	Hydrogen Production (VHTR signed project)
HTR	High-temperature gas-cooled reactor
ISAM	Integrated safety assessment methodology
LFR	Lead-cooled fast reactor
M&C	Materials and Chemistry (SCWR project)
MAT	Materials (VHTR project)
MOU	Memorandum of Understanding
MSR	Molten salt reactor
MWG	Methodology Working Group
PA	Project Arrangement
PG	Policy Group
PMB	Project Management Board
PP	Physical protection or project plan
PR	Proliferation resistance
PR&PP	Proliferation resistance and physical protection
PRPPWG	Proliferation Resistance and Physical Protection Working Group
PSSC	Provisional System Steering Committee
RSWG	Risk and Safety Working Group
SA	System arrangement
SCWR	Supercritical-water-cooled reactor
SDC	Safety design criteria
SFR	Sodium-cooled fast reactor
SIA	System Integration and Assessment (SFR project)
SIAP	Senior Industry Advisory Panel
SO	Safety and Operation (SFR signed project)
SRP	System research plan
SSC	System Steering Committee
TD	Technical Director
TF	Task force
TH&S	Thermal-hydraulics and Safety (SCWR signed project)
TS	Technical Secretariat
VHTR	Very-high-temperature reactor
WG	Working group

Technical terms

ADS	Accelerator-driven system
AGR	Advanced gas-cooled reactor (United States)
ALFRED	Advanced lead fast reactor European demonstrator
ASTRID	Advanced sodium technological reactor for industrial demonstration

ATHLET	Analysis of Thermal-hydraulics of Leaks and Transients
ATR	Advanced Test Reactor (at INL - USA)
AVR	Arbeitsgemeinschaft VersuchsReaktor
BWR	Boiling Water Reactor
CANDLE	Constant Axial shape of Neutron flux, nuclide densities and power shape During Life of Energy producing reactor (Code)
CATHARE	Code for Analysis of Thermal-hydraulics during an Accident of Reactor and Safety Evaluation
CEFR	China experimental fast reactor
CFD	Computational fluid dynamics
CGR	Crack growth rate
CLEAR	China Lead-based Reactor
COL	Combined construction and operating license
CRP	Co-ordinated research project
DHR	Decay heat removal
DNB	Departure from nucleate boiling
DHT	Deteriorated heat transfer
DU	Depleted uranium
ELFR	European lead fast reactor
ESFR	Example sodium fast reactor
EVOL	Evaluation and viability of liquid fuel fast reactor system (Euratom FP7 Project)
FSA	Fuel subassembly
FHR	Fluoride salt-cooled high-temperature reactor
FOAK	First-of-a-kind
GHG	Greenhouse gas
GTHTR	Gas turbine high-temperature reactor cogeneration
GSAR	Group on the Safety of Advanced Reactors
GT-MHR	Gas turbine-Modular Helium Reactor
GV	Guard vessel
HANARO	High-flux advanced neutron application reactor
HF	Hydrogen fluoride
HLM	Heavy liquid metal
HPLWR	High-performance light water reactor
HTGR	High-temperature gas-cooled reactor
HTR-PM	High-temperature gas-cooled reactor power generating module
HTR-10	High-temperature gas-cooled test reactor with a 10 MWth capacity
HTSE	High-temperature steam electrolysis
HTTR	High-temperature test reactor
IHX	Intermediate heat exchanger
IRRS	Integrated Regulatory Review Service
JSFR	Japanese sodium-cooled fast reactor
LBL	Leach-burn-leach
LOCA	Loss-of-coolant accident
LWR	Light water reactor
MA	Minor actinides
MC	Monte Carlo
MELCOR	Methods for estimation of leakages and consequences of release (NRC code by SNL)
MOSART	Molten salt actinide recycler and transmitter
MOU	Memorandum of Understanding
MOX	Mixed Oxide Fuel
MSFR	Molten Salt Fast Reactor
MYRRHA	Multi-purpose Hybrid Research Reactor for High-tech Applications
NGNP	New generation nuclear plant
NHDD	Nuclear hydrogen development and demonstration
NPP	Nuclear power plant
NSTF	Natural Convection Shutdown Heat Removal Test Facility

ODS	Oxide dispersion-strengthened
PASCAR	Proliferation-resistant, Accident-tolerant, Self-supported, Capsular and Assured Reactor
PBMR	Pebble-bed modular reactor
PDC	Plant dynamics code
PGSFR	Prototype Generation IV Sodium-Cooled Fast Reactor
PHX PRACS	Pool Reactor Auxiliary Cooling System heat exchanger
PIE	Post-irradiation examinations
PWR	Pressurised water reactor
PYCASSO	Pyrocarbon irradiation for creep and shrinkage/swelling on objects
R&D	Research and Development
RV	Reactor Vessel
SCC	Stress corrosion cracking
SDG	Safety design guideline
SEM	Scanning electron microscopy
SCW	Supercritical water
SG	Steam generator
SI	Sulphur Iodine
SMART	System-integrated Modular Advanced Reactor
SMR	Small modular reactor
SSTAR	Small, sealed, transportable, autonomous reactor
STELLA	Sodium integral effect test loop for safety simulation and assessment
TEM	Transmission electron microscopy
THTR	Thorium high-temperature reactor
TMSR	Thorium molten salt reactor
TORIA	Thorium-optimised Radioisotope Incineration Arena
TRISO	Tri-structural isotopic (nuclear fuel)
TRU	Transuranic
UCO	Uranium oxycarbide
ULOF	Unprotected loss of flow
XRD	X-ray diffraction
ZrC	Zirconium carbide

Organisations, programmes and projects

ANL	Argonne National Laboratory
ANS	American Nuclear Society
ANSTO	Australian Nuclear Science and Technology Organization
ANRE	Agency for Natural Resources and Energy (Japan)
ARC DOE	Office of Advanced Reactor Concepts (United States)
ASME	American Society of Mechanical Engineers
ASN	Autorité de Sureté Nucléaire (French nuclear safety authority)
CAEA	China Atomic Energy Authority (China)
CEA	Commissariat à l'énergie atomique et aux énergies alternatives (France)
CIAE	China Institute of Atomic Energy
CNL	Canadian Nuclear Laboratories
CNRS	Centre national de la recherche scientifique (France)
CNSC	Canadian Nuclear Safety Commission
DEN	Direction de l'énergie nucléaire (Commissariat à l'énergie atomique, CEA)
DOE	Department of Energy (United States)
EC	European Commission
ENEA	Italian National Agency for New Technologies, Energy and Sustainable Economic Development
ENSI	Swiss Federal Nuclear Safety Inspectorate
EU	European Union
FP7	7th Framework Programme
IAEA	International Atomic Energy Agency

ICN	Institute of Nuclear Research (Romania)
IFNEC	International Framework for Nuclear Energy Cooperation
INET	Institute of Nuclear and New Energy Technology
INL	Idaho National Laboratory (United States)
INPRO	International Project on Innovative Nuclear Reactors and Fuel Cycles (IAEA)
IPPE	Institute for Physics & Power Engineering (Russia)
IRSN	Institut de Radioprotection et de Sureté Nucléaire
ITU	Institute for Transuranium Elements
LEADER	Lead-cooled European Advanced Demonstration Reactor
JAEA	Japan Atomic Energy Agency
JRC	Joint Research Centre (Euratom)
KAERI	Korea Atomic Energy Research Institute
KEPCO	Korea Electric Power Corporation
KIT	Karlsruhe Institute of Technology (Germany)
MDEP	Multinational Design Evaluation Programme
MOST	Ministry of Science and Technology (China)
MTA	Hungarian Academy of Sciences Centre for Energy Research
NEA	Nuclear Energy Agency
NIKIET NA	Dollezhal Research and Development Institute of Power Engineering
NPIC	Nuclear Power Institute of China
NRA	Nuclear Regulation Authority
NRC	Nuclear Regulatory Commission (United States)
NRCKI	National Research Centre Kurchatov Institute (Russia)
NRCan	Department of Natural Resources (Canada)
NRG	Dutch Nuclear Safety Research Institute
NUBIKI	Hungarian Nuclear Safety Research Institute
NUTRECK	Nuclear Transmutation Energy Research Centre
OECD	Organization for Economic Co-operation and Development
ORNL	Oak Ridge National Laboratory (United States)
PBMR Pty	Pebble Bed Modular Reactor (Pty) Limited (South Africa)
PSI	Paul Scherrer Institute (Switzerland)
RIAR	Research Institute of Atomic Reactors
SUSEN	The Sustainable Energy Project (Czech Republic)
VTT	Valtion Teknillinen Tutkimuskeskus (Technical Research Centre of Finland)
VUJE	Slovakian engineering company

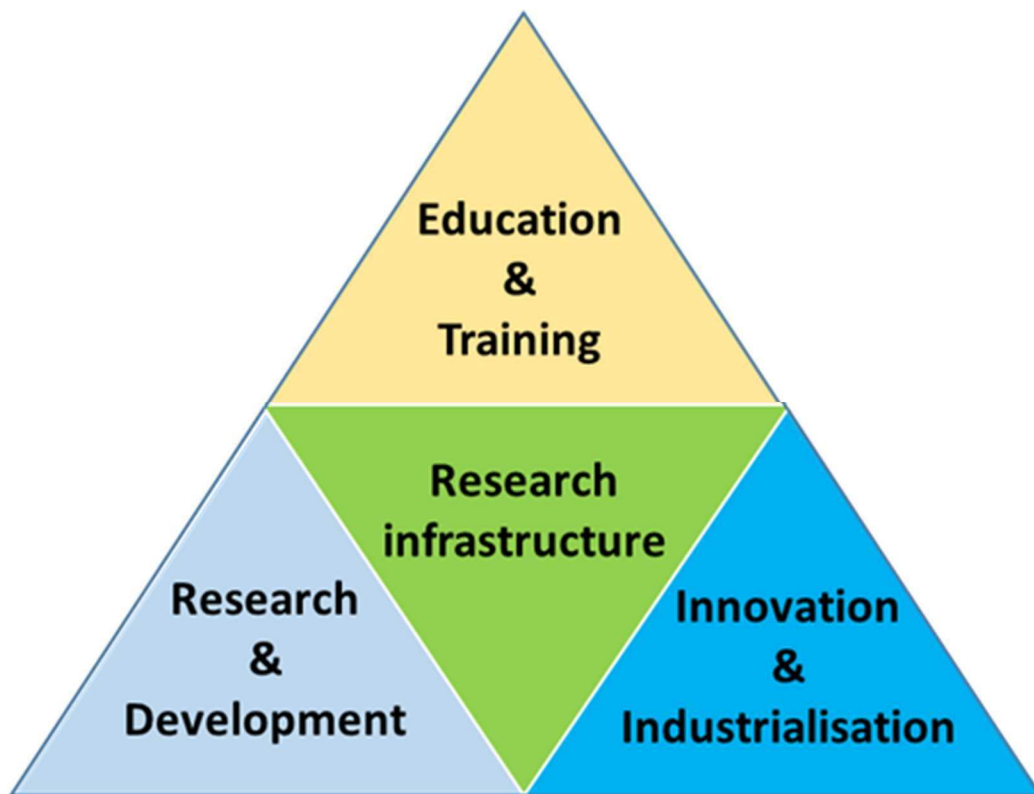

A report produced by



www.gen-4.org

RD-TF

R&D Infrastructure Task Force