



# ENERGY CONVERSION

Richard Stainsby

National Nuclear Laboratory, UK

21 September 2017



Canadian Nuclear  
Laboratories

Laboratoires Nucléaires  
Canadiens



# Meet the presenter



Dr. Richard Stainsby is a mechanical engineer with a PhD in computational fluid dynamics and heat transfer. He is Chief Technologist for Advanced Reactors and Fuel cycles at the UK's National Nuclear Laboratory, having worked both in research facilities and industry before joining NNL.

Richard has spent the last 32 years working on light water, high temperature gas reactors (HTGR) and on liquid metal and gas fast reactors. He has worked on contracts for PBMR in South Africa on core design and whole plant simulation, for the National Nuclear Regulator, also in South Africa, and for the USNRC on the development of licensing tools for HTGRs.

Richard is a past Chair of the GIF GFR System Steering Committee and a current Euratom member of the GIF SFR System Steering Committee. He has led two European projects (GCFR-STREP and GoFastR) on gas cooled fast reactors (GFR) and was a leader of the innovative architecture and balance of plant sub-project within the Euratom CP-ESFR project between 2009-2013.



# Power conversion cycles for a nuclear power system



- The linkage between a nuclear reactor and its power conversion system is more intimate than for a fossil-fuelled plant.
- The reactor must supply a flow of heat that is controllable and of sufficient quality to match the requirements of the power conversion system (or engine).
- The engine must supply a stable flow of coolant to the reactor inlet that respects its material limits and neutronic requirements.
- A reactor is a temperature-dependent heat source – not fuel flow dependent as in a fossil-fuelled plant.

# Why are Gen IV reactors different from other nuclear reactors ?



- At least 3 concepts are intended to operate at high-temperature – so we need heat engines that can exploit high temperature heat sources efficiently.
  - A conventional Rankine (steam) cycle will not make best use of heat of such high quality.
- The architecture of some high-temperature systems is based on using the fluid returning from the power conversion system to cool the reactor pressure vessel (RPV).
  - This places an upper limit on the amount of waste heat recovery (recuperation) we can employ.
- Two of the concepts are gas cooled. All gas-cooled reactors use a low density coolant that consumes a lot of power to circulate.
  - The coolant circulation power can consume a significant fraction of the power output,
  - It is important to minimise the core pressure drop and to minimise the primary flow rate ( $P_c \propto Q^3$ ).

# Basic Structure of a Thermal Power Station

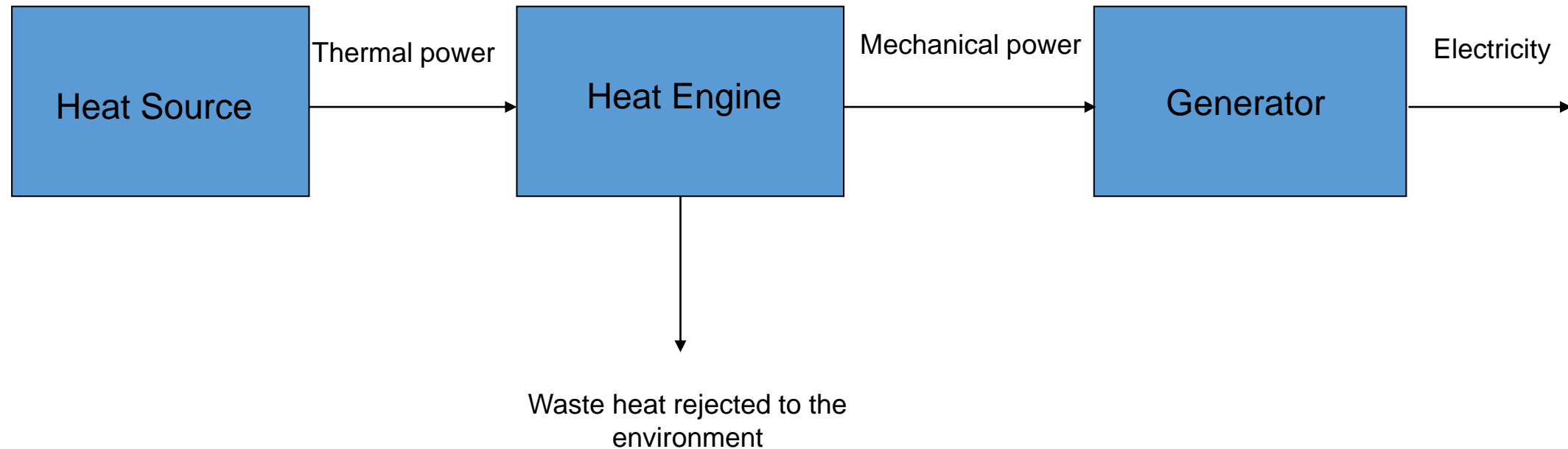

# A Typical Fossil-Fuelled Power Station

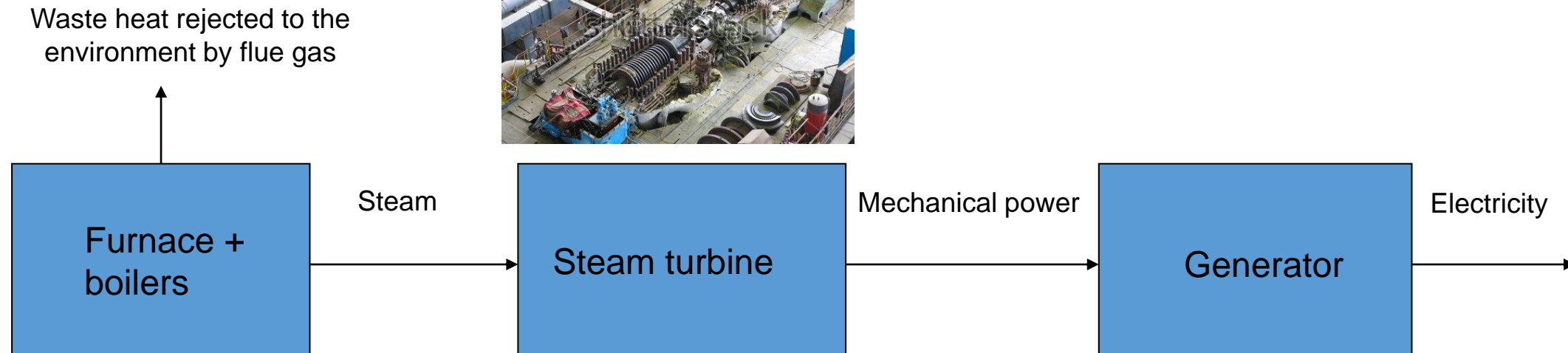

Waste heat rejected to the environment by cooling water – to a river/sea or to atmosphere

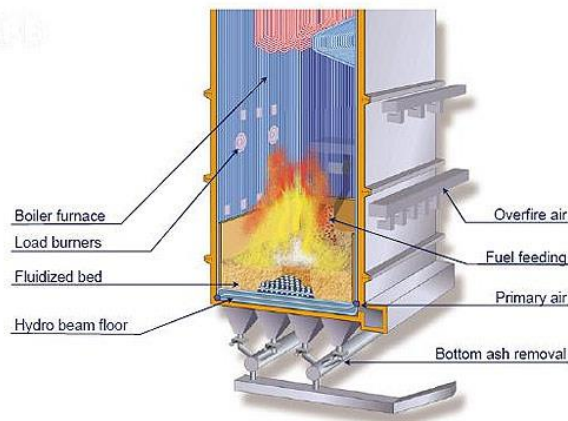

# A Typical Gen I/II/III Nuclear Power Station



Steam

Mechanical power

Electricity

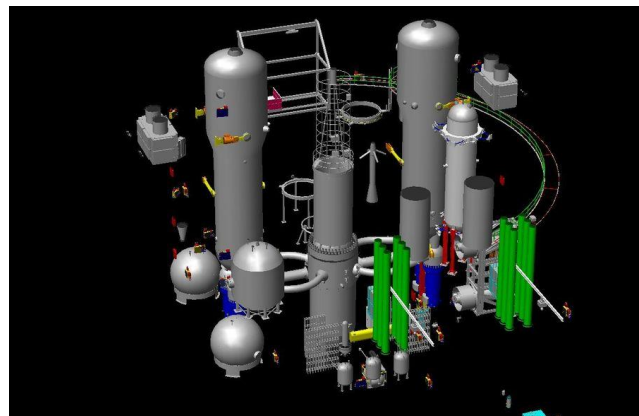
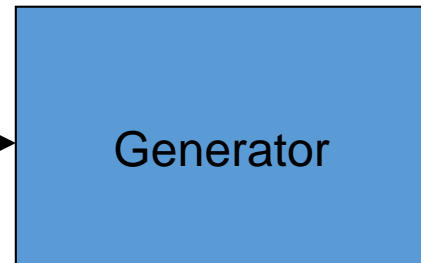
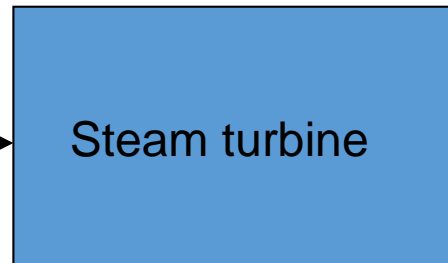
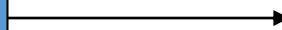
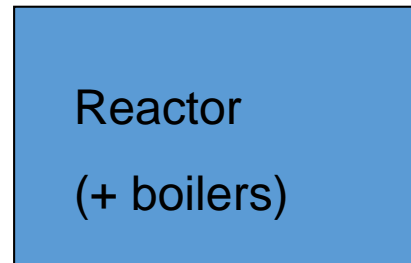

Waste heat rejected to the environment by cooling water – then to a river/sea or to the atmosphere



# Gen IV Nuclear Power Stations

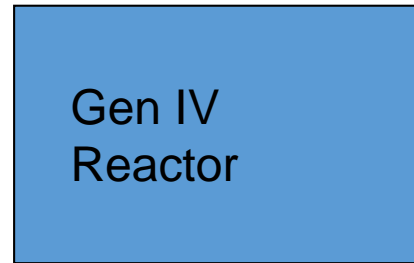
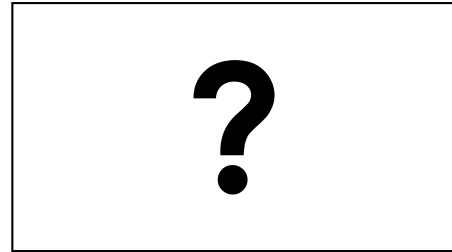
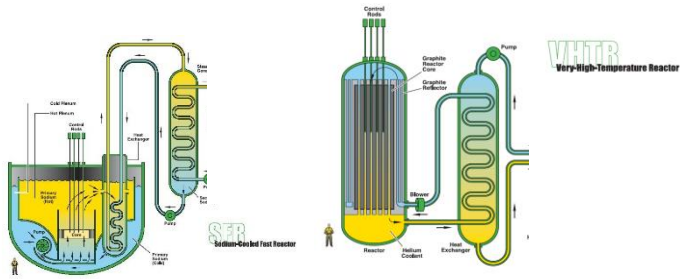

Heat

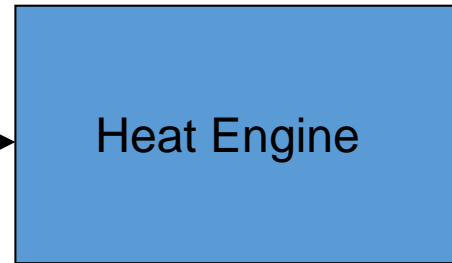

Mechanical power

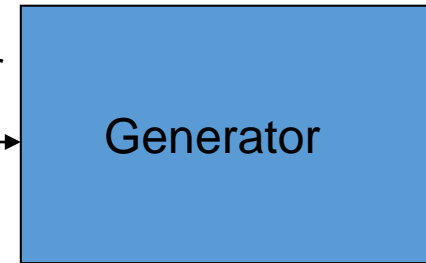

Electricity

Waste heat rejected to the environment  
by cooling water – to a river/sea or to  
atmosphere

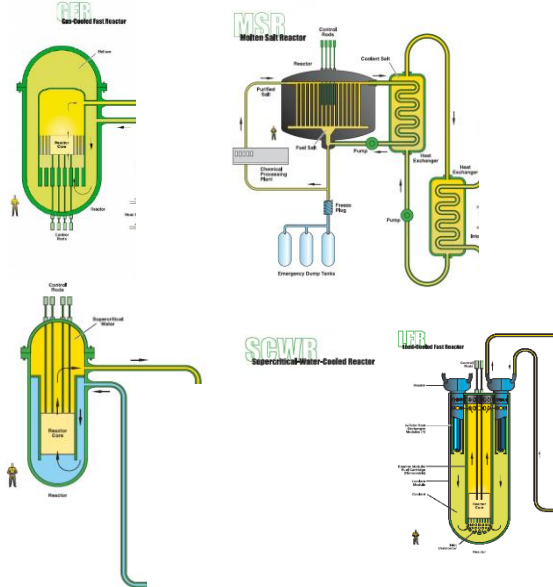



# Questions

- How much mechanical power do we get for a given amount of thermal power (cycle efficiency) ?
- Why do we have to reject heat to the environment ?
- How do we maximise the efficiency of the whole system ?
- What do we put in the “heat engine” box for Gen IV reactors ?

## Answers or where to find them

- The answers to the first three questions are found in the First and Second Laws of thermodynamics.
- The answer to the fourth question depends on the first three and on matching the heat engine to the characteristics of the reactor.

# The first three questions

- How much mechanical power do we get for a given amount of thermal power (cycle efficiency) ?
- Why do we have to reject heat to the environment ?
- How do we maximise the efficiency of the whole system ?

# The First Law of Thermodynamics

“When any closed system is taken through a cycle, the net work delivered to the surroundings is proportional to the net heat taken from the surroundings” or  $W = Q_{IN} - Q_{OUT}$

- For the steady operation of a closed-cycle system we have:

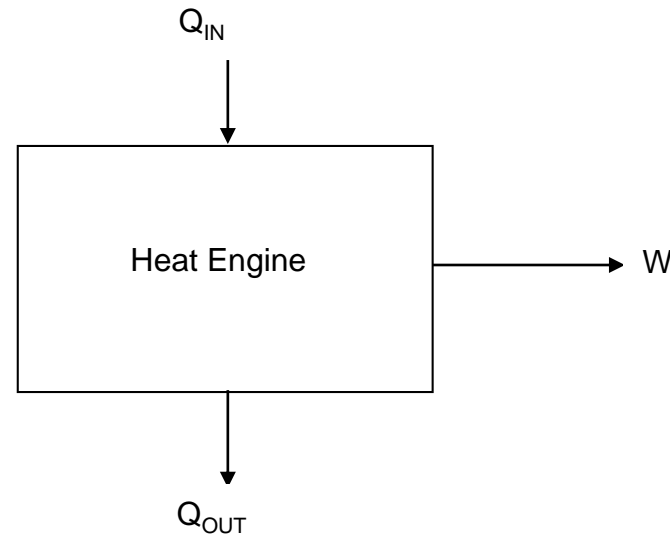

*Cycle efficiency*  $= \eta = \text{work done} / \text{heat supplied} = W/Q_{IN} = (Q_{IN} - Q_{OUT})/Q_{IN}$

# The First Law continued

- To maximise efficiency we need to maximise the work output for a given heat input. So we need to make the heat supplied  $Q_{IN}$  large relative to the heat rejected  $Q_{OUT}$ .
- The ideal would be to make  $Q_{OUT} = 0$  and there is nothing in the First Law to prevent this.
- Unfortunately, we have the Second Law ...

# The Second Law of Thermodynamics



“It is impossible to construct a system which will operate in a cycle, extract heat from a reservoir, and do an equivalent amount of work on the surroundings”

(for reservoir, read heat source or heat sink)

- The second law is a statement that some heat must always be rejected from the cycle and that, as a consequence, the cycle efficiency will always be less than unity.

# Heat engine operating between two reservoirs

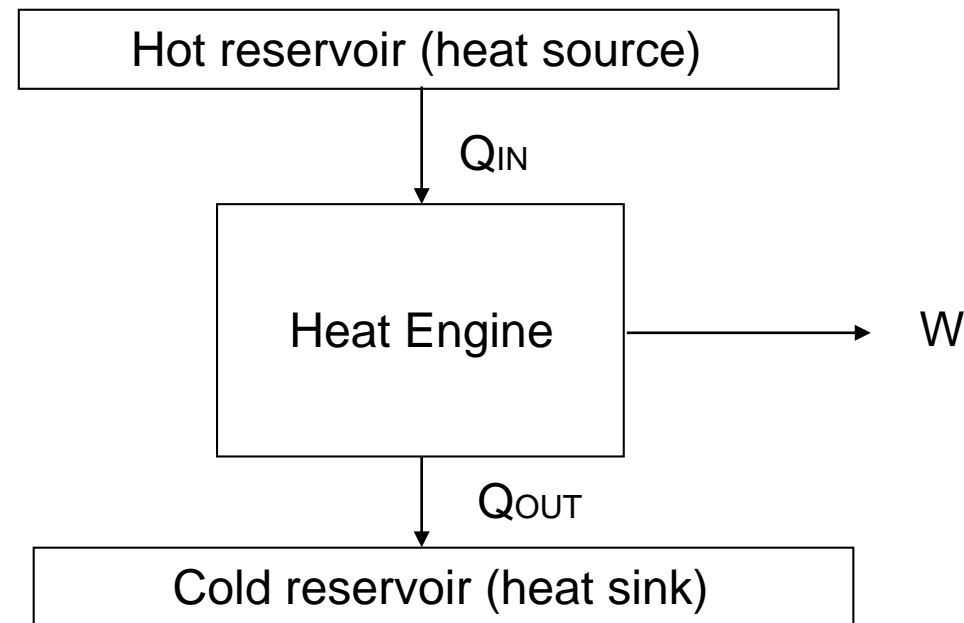

# Consequences of the first and second laws



- Taken together, the first law states that the work produced cannot exceed the heat supplied and the second law states that, in fact, the work produced must be less than the heat supplied, or  $W < Q_{IN}$ .
- Summary:
  - First Law – “there is no such thing as a free lunch”
  - Second Law – “you don’t even get as much lunch that you think you have paid for” !



# Corollaries of the Second Law



- There are eight “corollaries” of the second law

**corollary:** *noun (plural corollaries)*

a proposition that follows from (and is often appended to) one already proved.

- a direct or natural consequence or result

# Corollary 1

- Corollary 1: “It is impossible to construct a system which will operate in a cycle and transfer heat from a cooler to a hotter body without work being done on the system by the surroundings”
- Consequence - as the system must reject heat, this heat must be rejected at a temperature not less than that of the surroundings if we wish to maximise the work output for a given heat input.
- Impact for energy conversion systems – the practical minimum temperature in the cycle must be about 30°C ( $T_{OUT} \sim 303 \text{ K}$ )

# Reversibility

- Definition: **Reversibility** - “when a system undergoes a reversible process the fluid and the surroundings can be restored to their original states”
- A reversible process is one in which everything can be reversed: heat input becomes heat output and work output becomes work input, such that the system and its surroundings ends up in its original state.
- This is an idealisation and all real processes are irreversible through the action of factors such as friction.
- An ideal heat engine would be fully reversible, whereas a real heat engine would be irreversible.

## Corollary 2

- Corollary 2: “It is impossible to construct a heat engine operating between two reservoirs which will have a higher efficiency than a reversible heat engine operating between the same two reservoirs.”
- Consequence – for a real cycle operating between given maximum and minimum temperatures, there is a theoretical maximum efficiency which it cannot exceed – this is the efficiency of a reversible cycle operating between the same two temperatures - known as the Carnot efficiency, written as:

$$\eta_c = (T_{IN} - T_{OUT}) / T_{IN} = (1 - T_{OUT} / T_{IN})$$

- Impact for Gen IV reactors:
  - For VHTR with  $T_{IN} = 1000^{\circ}\text{C}$  (1273K) ,  $\eta_c = 0.76$
  - For GFR with  $T_{IN} = 850^{\circ}\text{C}$  (1123 K),  $\eta_c = 0.73$
  - For SFR with  $T_{IN} = 550^{\circ}\text{C}$  (823 K),  $\eta_c = 0.63$

# Corollary 5

- Corollary 5 – simplified definition – “the efficiency of heat engine is maximised if heat is added at constant temperature and heat is rejected at a constant (but obviously lower) temperature”
- Consequence: We must minimise the range of temperatures over which the heat is added to the cycle – the ideal is to add this at constant temperature. Similarly we must minimise the range of temperatures over which heat is rejected from the cycle – again the ideal is constant temperature.
- Impact for Gen IV reactors – this is good news for liquid metal-cooled reactors (SFR & LFR) but bad news for gas-cooled systems (VHTR & GFR)
  - Minimising High coolant pumping power in gas-cooled reactors requires a large core inlet-outlet coolant temperature rise

# What about the other corollaries ?

- Corollary 3 states that the efficiencies of all reversible heat engines operating between the same two reservoirs are identical – a consequence of Corollary 2.
- Corollary 4 states that there must be an absolute zero of temperature (regardless of the units of measurement used – the temperature of  $T_{OUT}$  at which  $\eta_c = 1$ )
- Corollary 6 (the “Clausius Inequality”) follows from Corollary 5 and this and forms the basis by which Corollary 7 defines a new property called entropy.
- Corollary 8 states that the change in entropy is zero for an adiabatic reversible process and is always  $> 0$  for all real adiabatic processes
  - entropy ( $s$ ) is used as a measure of irreversibility of real processes occurring in real components (e.g., compressors and turbines) through the parameter **isentropic efficiency**.

# Work Ratio

- Whilst the objective of the heat engine is to produce net work, the engine produces positive work but some work is consumed by the engine itself (negative work):
  - Feedwater pumps (Rankine cycle)
  - Condensate extraction (Rankine cycle)
  - Condenser vacuum pumps (Rankine cycle)
  - Cooling water pumps
  - Compressor work (Brayton cycle)
- For a heat engine attached to a nuclear reactor we have to consider the work required to circulate the coolant within the primary circuit.
- The work ratio is define as:
$$r_w = \text{net work} / \text{positive work}$$
- The cycle efficiency is maximised if  $r_w$  is as large as possible

# The steam Rankine cycle

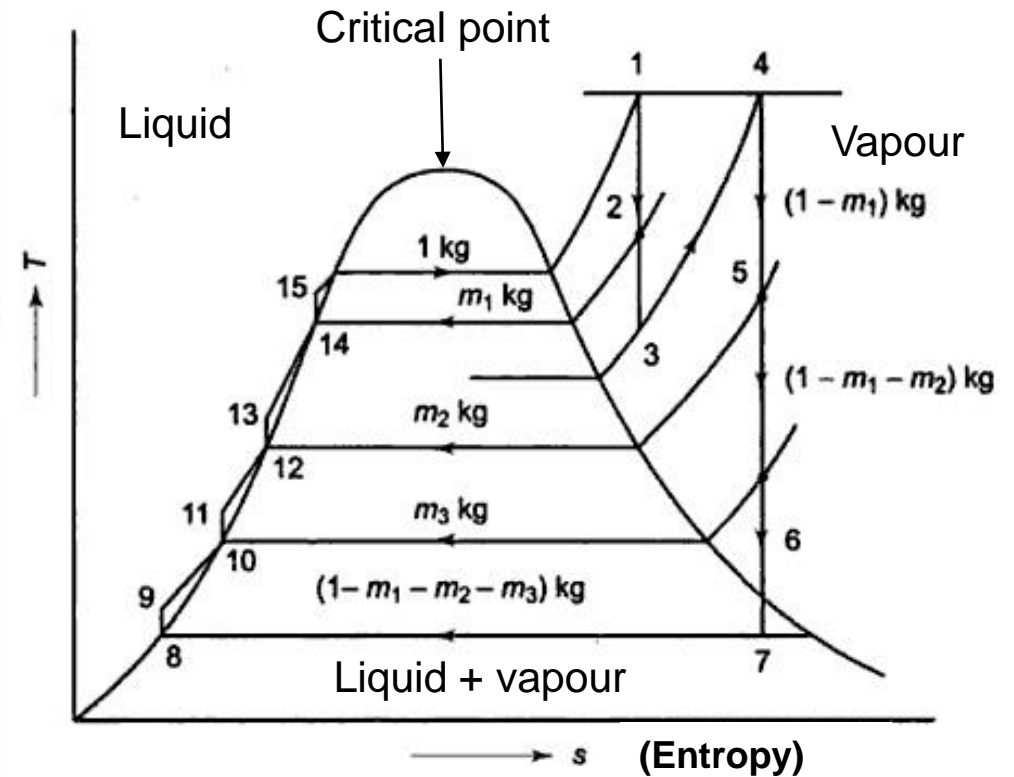
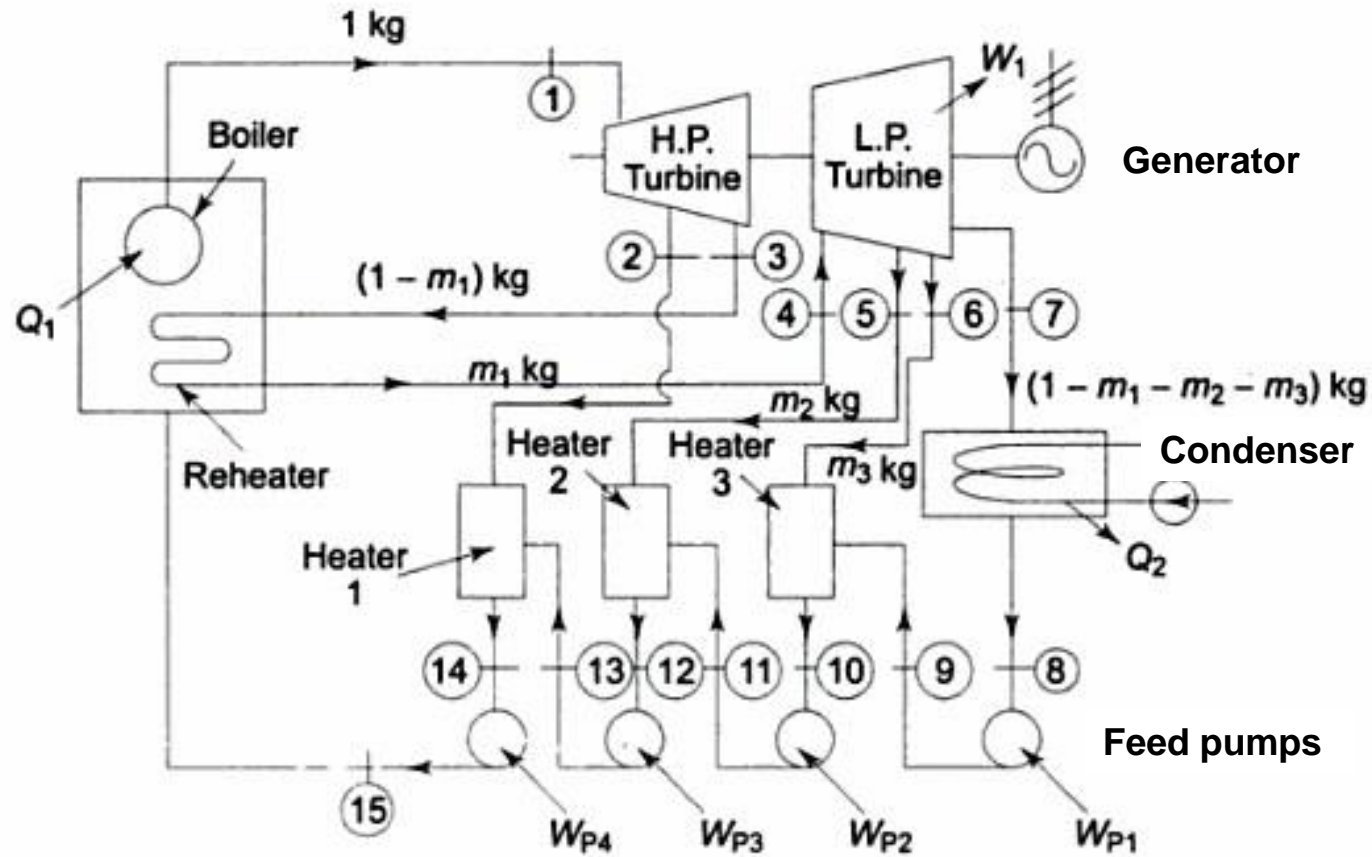

- Rankine cycle with reheat and feed heating (typical of an AGR)



# Rankine cycle – principles of operation



- Water is pressurised using a series of mechanical feed pumps
  - As water is almost incompressible it requires little power to gain a large increase in pressure for a given mass flow rate → good work ratio.
- Feed heaters recover heat from bled steam from the turbine casing drains to pre-heat feed water almost to its boiling temperature.
- Heat input to boiler changes phase from liquid to dry vapour and further heat input superheats the vapour.
- High pressure and temperature vapour is expanded through the HP turbine.
- Exhaust from HP turbine is reheated in the boiler and fed to subsequent intermediate and LP turbines.
- Wet vapour exhaust at just above ambient temperature is condensed back to liquid water and passed back through the feed train to the boiler.
- High efficiency is achieved because of excellent work ratio and bulk of heat addition and heat rejection both occur as constant temperature processes.
  - Corollary 5 of the 2<sup>nd</sup> law

# Gas Brayton (regenerative) cycle

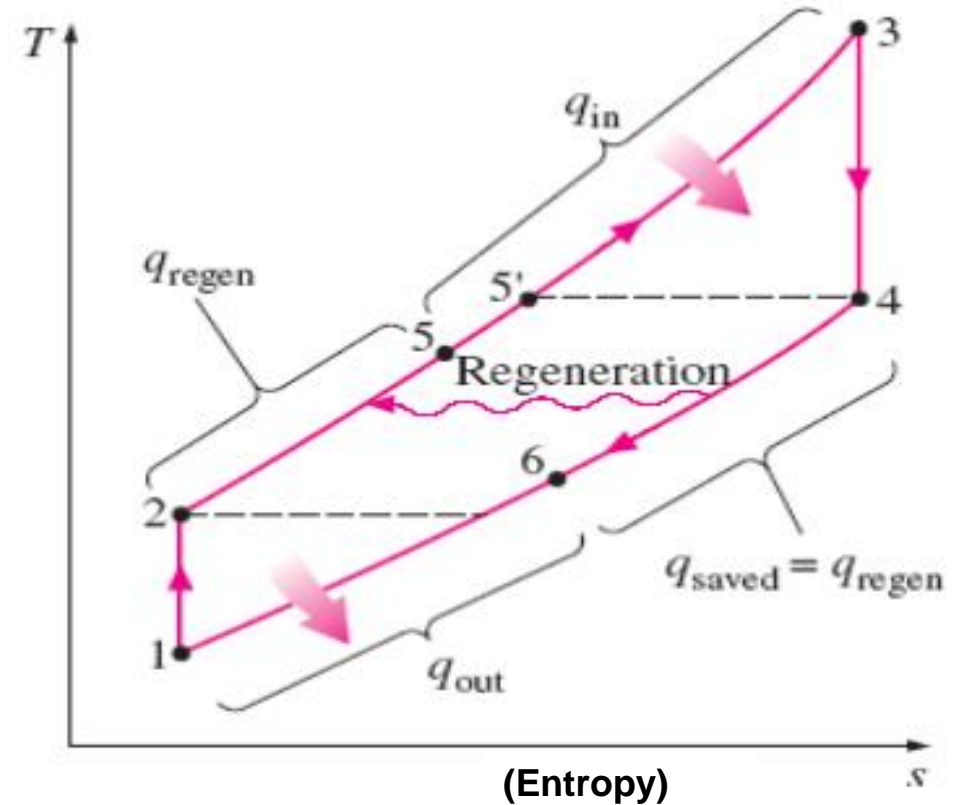
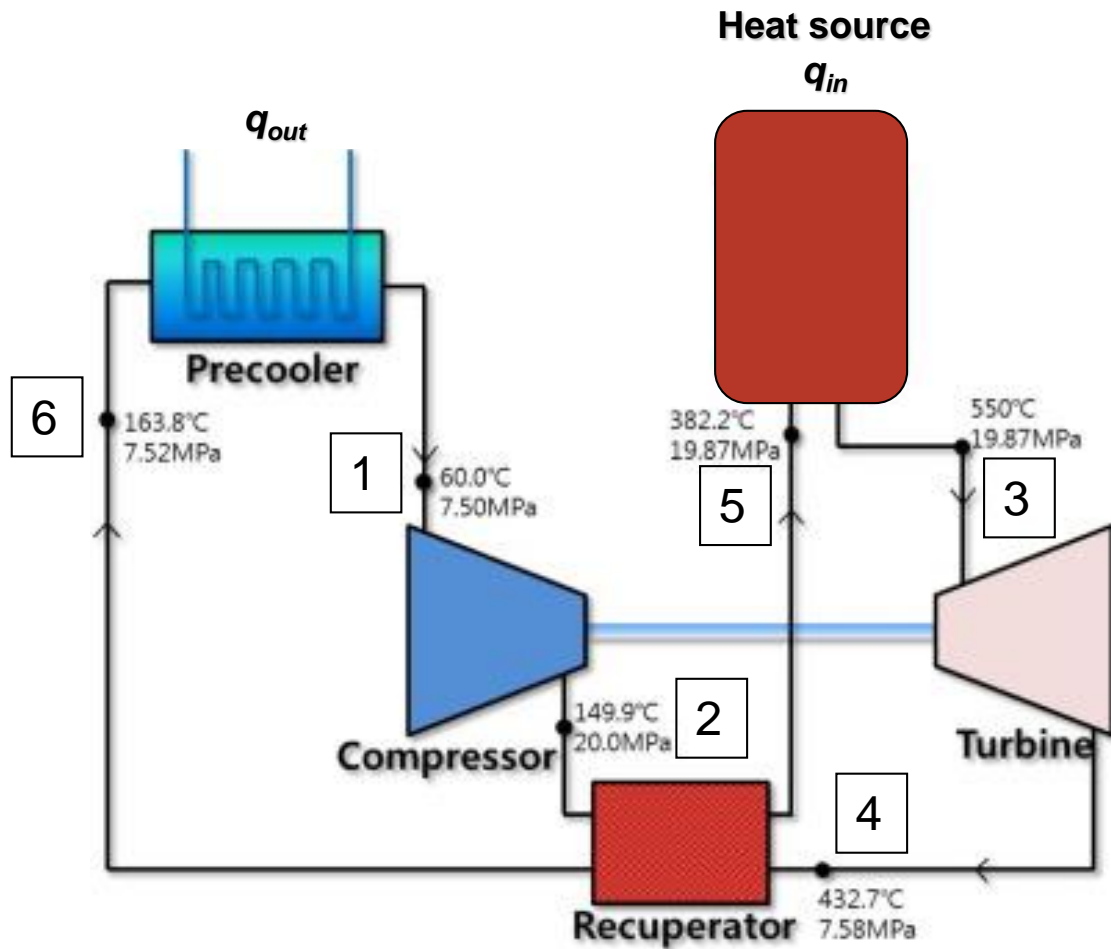

- Closed cycle gas turbine with recuperator to re-use the waste heat from the turbine exhaust

# Brayton cycle – principles of operation

- Compressor works like a turbine in reverse:
  - Consumes some of the work produced by the turbine and increases fluid temperature and pressure to  $T_2$  and  $P_2$ .
- Heat, captured from the turbine exhaust, is added to high pressure gas in the recuperator.
- Further heat is added from the heat source (a reactor in our case)
- Hot gas (at  $T_3$ ) is expanded through the turbine back to just above the compressor inlet pressure ( $P_1$ ) to produce work.
- The constant pressure lines on the T-s diagram diverge slowly with increasing temperature, such that the temperature drop (and hence enthalpy change) over the turbine is greater than the temperature rise over the compressor.
  - The difference between the enthalpy drop over the turbine and the enthalpy gain over the compressor is the net work produced by the cycle.
  - The difference between  $T_1$  and  $T_3$  must be large to achieve a reasonable work ratio and, therefore, a reasonable thermal efficiency
  - The recuperator increases the temperature and reduces the temperature range over which heat is added, and reduces the temperature and range over which heat is rejected
    - The recuperator creates a closer approximation to a Carnot cycle

# Combined Cycle for high temperature reactors (GFR in this example)

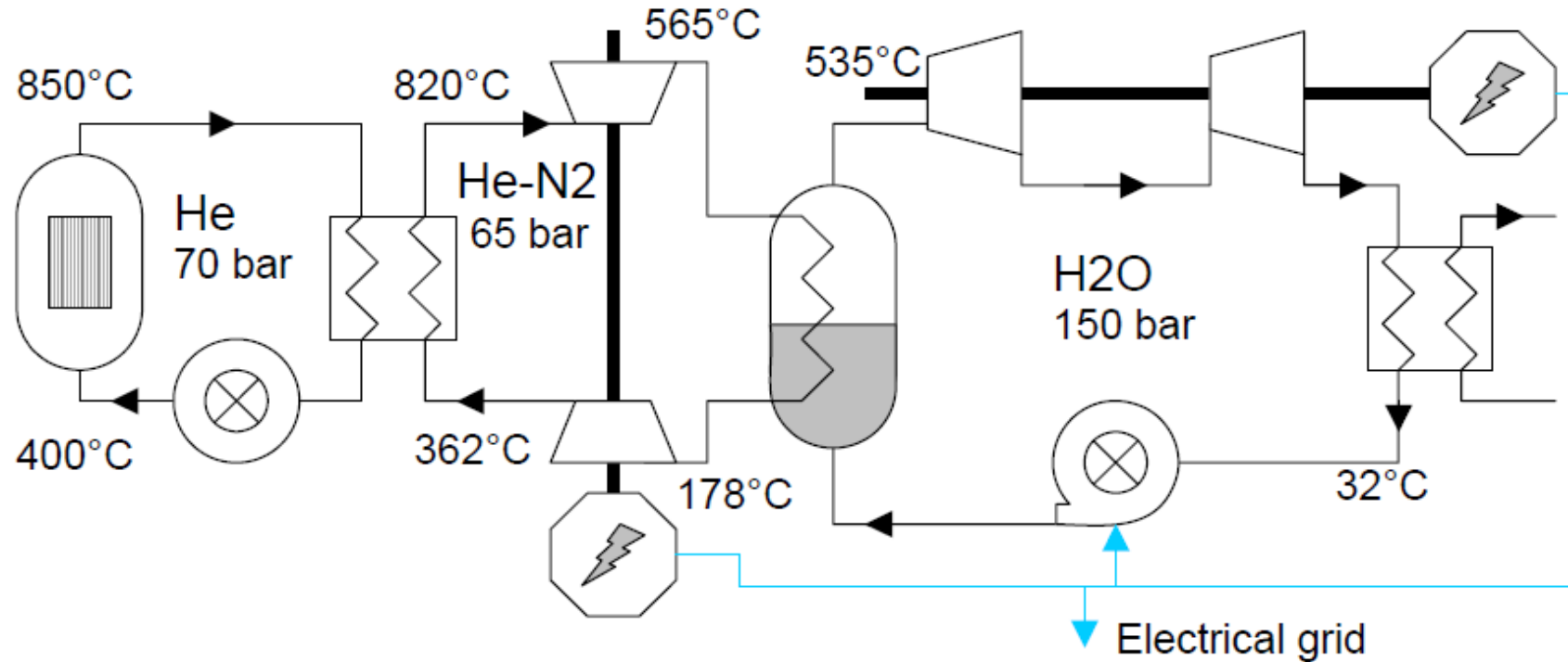

1. Direct cycle,  $T_{in} = 480^{\circ}\text{C}$ :  $\eta \sim 47.5\%$
2. Indirect cycle,  $T_{in} = 480^{\circ}\text{C}$ :  $\eta \sim [45.5 - 45.6]\%$
3. Direct cycle,  $T_{in} = 400^{\circ}\text{C}$ :  $\eta \sim 44.8\%$
- 4. Indirect combined cycle,  $T_{in} = 400^{\circ}\text{C}$ :  $\eta \sim [44.4 - 44.7]\%$**
5. Indirect cycle,  $T_{in} = 400^{\circ}\text{C}$ :  $\eta \sim [42.4 - 42.8]\%$

# Why use a combined cycle gas turbine system ?

- Cost of turbines
  - Steam turbines are cheap (simpler materials)
  - Gas turbines are expensive
- Cost of heat exchangers
  - Heat recovery steam generators are a low-risk technology
  - Highly effective gas to gas recuperators are expensive
- Combined cycles have a good track record of use in many fossil-fired CCGT power plants.

## Principle of operation:

- We only need the gas turbine to use the highest-temperature fraction of the heat – the waste heat from the turbine exhaust is hot enough to generate high-quality steam.
- The cycle is biased so that the bulk of the power is generated by the steam turbine to minimise the size (and cost) of the gas turbine.

# Supercritical CO<sub>2</sub> - an option for SFR and a fall-back option for GFR

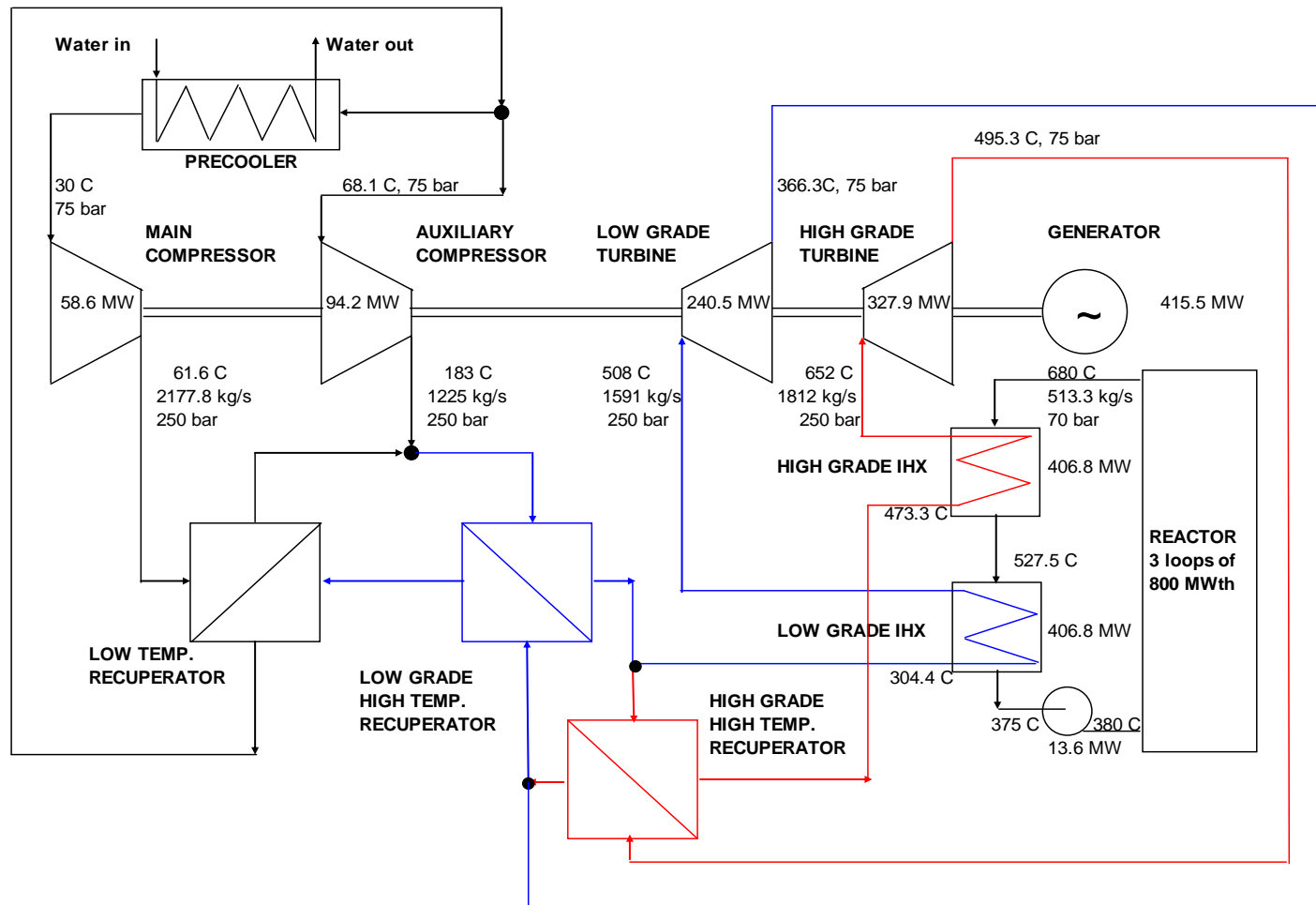





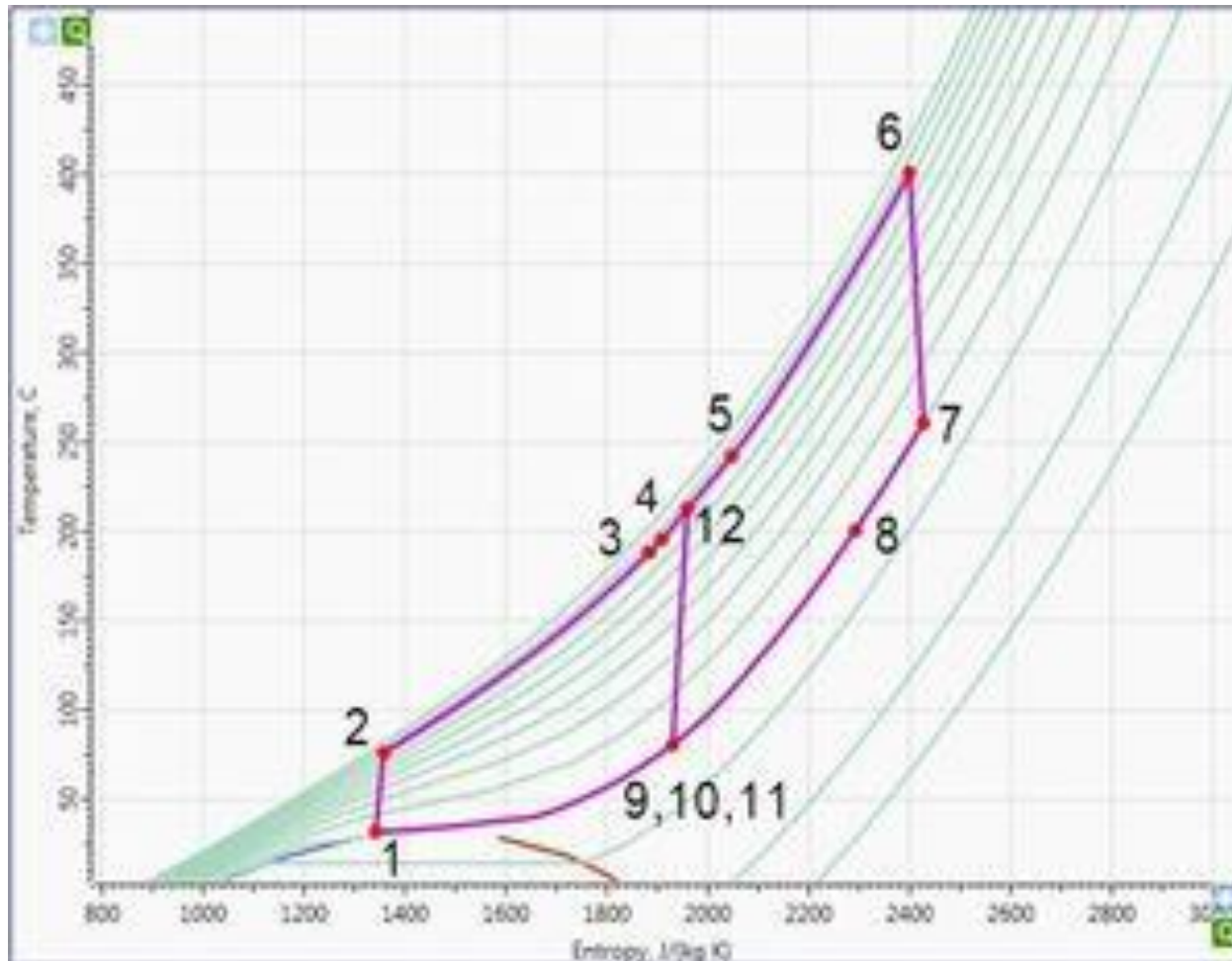

- For GFR a supercritical CO<sub>2</sub> recompression cycle can deliver similar performance for to a helium Brayton cycle operating at 850°C for a core outlet temperature of 680°C:
- $\eta = 46\%$

# Supercritical CO<sub>2</sub> cycles – principles of operation



- Constant pressure (CP) lines bunch up as they pass over the critical point.
- Compression of the fluid at this point requires a small amount of work.
- CP lines diverge very quickly to the right of the critical point
- Large difference between turbine and compressor work can be obtained for moderate temperature difference.
- Working close to the critical point presents thermodynamic challenges
  - The “recompression cycle” features parallel main and auxiliary compressors to manage the thermodynamic problems encountered close to the critical point.
- Critical Point for CO<sub>2</sub>:
  - 73.9 bar (abs) and 31.1°C

# Direct or indirect cycles? – that is the question

- Direct cycle –
  - No primary-secondary temperature drops 
  - No high-temperature heat exchanger 
  - Activation of turbomachine 
  - Oil-free bearings required (for gas systems) 
  - Cobalt-free alloys required 
  - Turbine must use reactor coolant as working fluid 



# Direct or Indirect continued

- Indirect cycle –
  - Primary-secondary temperature drops
  - High-temperature (high-risk) heat exchanger
  - No activation of turbomachine
  - Standard turbine technology
  - Simple (and standard) turbine alloys are required
  - Turbine can work with optimum working fluids



# Power conversion system options (GFR)

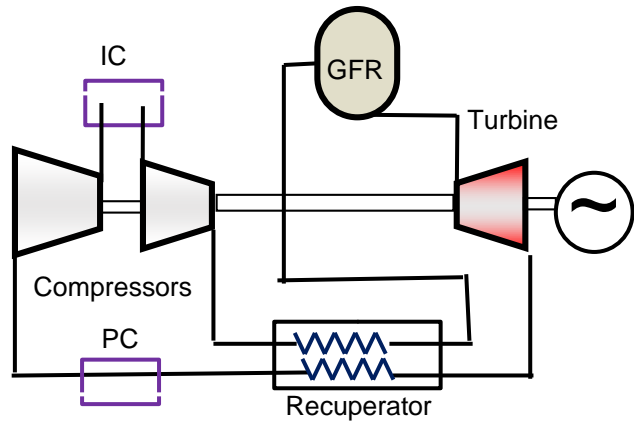

**Direct Recuperated Helium GT**

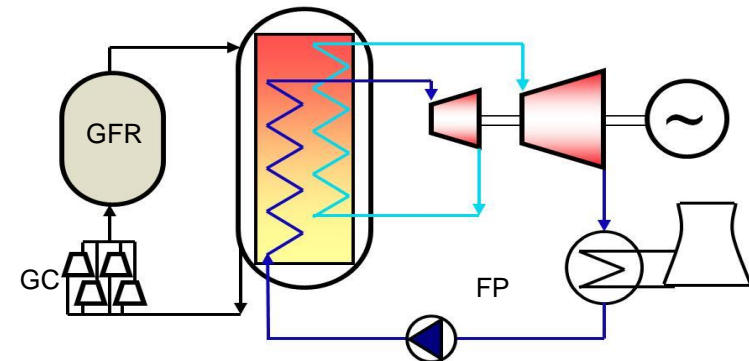

**Indirect Pure Steam Cycle**

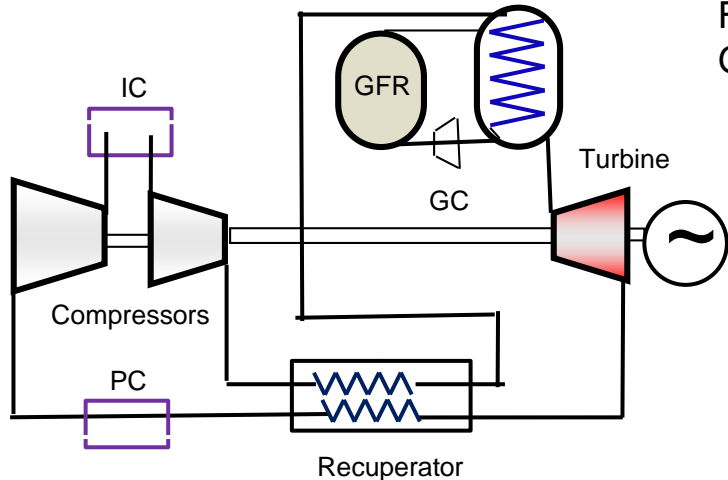

**Indirect Recuperated Helium GT**

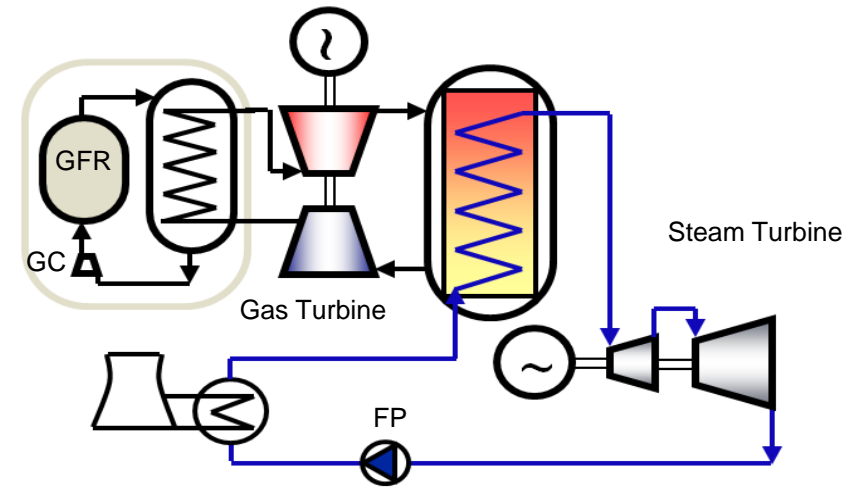

**Indirect CCGT**



PC – pre-cooler  
IC – Intercooler  
FP – Feed water pump  
GC – Gas circulators

Images courtesy of  
Chris Neeson, Rolls-Royce plc

# Maximising the efficiency of the whole system



1. A pre-requisite for high cycle efficiency is to operate between max. and min. temperatures that give a high Carnot efficiency.
2. Next, steps must be taken to minimise the temperature ranges over which heat is injected and rejected from the cycle:
  - Feed heating using steam in a Rankine (steam) cycle
    - Using bled steam from the last stages of the turbine to pre-heat feed water before entry to the boiler.
  - Recuperation in a Brayton (gas turbine) cycle
    - Using waste heat from the turbine to pre-heat gas before heat addition from the heat source.
3. Finally, steps must be taken to maximise the work ratio:
  - Minimise power associated with pumping or compression of the working fluid – and/or maximise turbine work.
  - Minimise pumping power of the primary coolant in the reactor.

# Matching Gen IV Reactors to heat engines: SFR



- The temperature range of SFR matches that required by the steam Rankine cycle very well to give high efficiency:
  - Historically, the Rankine cycle has been paired with SFR
  - Sodium-water interactions through steam generator tube leaks are the biggest problem
- Future SFR projects, such as the French ASTRID project propose to eliminate the steam cycle:
  - Short-term, but low efficiency option is to use a nitrogen Brayton cycle
  - Longer-term, high efficiency option is to use a supercritical CO<sub>2</sub> recompression cycle

# Matching Gen IV Reactors to heat engines: LFR



- Current LFR concepts are well matched to the steam Rankine cycle:
  - Lower core outlet temperature than SFR
  - No intermediate loop required
  - Efficiency is similar to that for SFR with a Rankine cycle.
- Future high-temperature LFR concepts can use a gas Brayton cycle

# Matching Gen IV Reactors to heat engines: gas reactors GFR and VHTR



- GFR and VHTR share similar core outlet temperatures:
  - Lowest risk and most economically favourable option for both reactors is a Brayton-Rankine combined cycle, with either a direct or indirect cycle gas turbine.
  - Most efficient is a fully recuperated direct gas turbine (Brayton) cycle, but this requires a technologically-demanding gas turbine and the reactor pressure vessel has to run at a moderately high temperature (~500°C)
- A fallback option for low temperature variants of both GFR and VHTR is the supercritical CO<sub>2</sub> recompression cycle.
- The steam Rankine cycle is the ultimate fallback option

# Matching Gen IV Reactors to heat engines: Molten salt reactors



- All options are available, in an indirect cycle arrangement and depends upon the design and operating temperatures of the specific molten salt reactor.
- As the MSR and MSFR operate at low pressure, one must guard against the power cycle working fluid entering the salt circuits, particularly in the case of a steam Rankine cycle.

# Matching Gen IV Reactors to heat engines: Supercritical water reactors



- Supercritical water reactors are generally an evolution of boiling water reactors.
- The power cycle choice is obvious for a direct cycle arrangement and it should be a supercritical steam Rankine cycle.
- It would be possible to use alternative power cycles for an indirect cycle plant, such as a supercritical CO<sub>2</sub> cycle.
  - There may be some economic benefits in using an S-CO<sub>2</sub> cycle as the turbomachinery is significantly smaller than for steam plant of the same power output.





# Upcoming webinars

25 October 2017

Estimating Costs of Gen IV Systems

Dr. Geoffrey Rothwell, NEA/OECD

29 November 2017

Feedback from Phenix and SuperPhenix

Dr. Joel Guidez, CEA, France

14 December 2017

Sustainability of Gen IV Nuclear Energy  
Systems

Dr. Christophe Poinssot, CEA, France